

SE

PROPERTY OF
SEGA SERVICE CENTRE
DO NOT REMOVE

MANX TT SuperBike

DELUXE TYPE

OWNER'S MANUAL

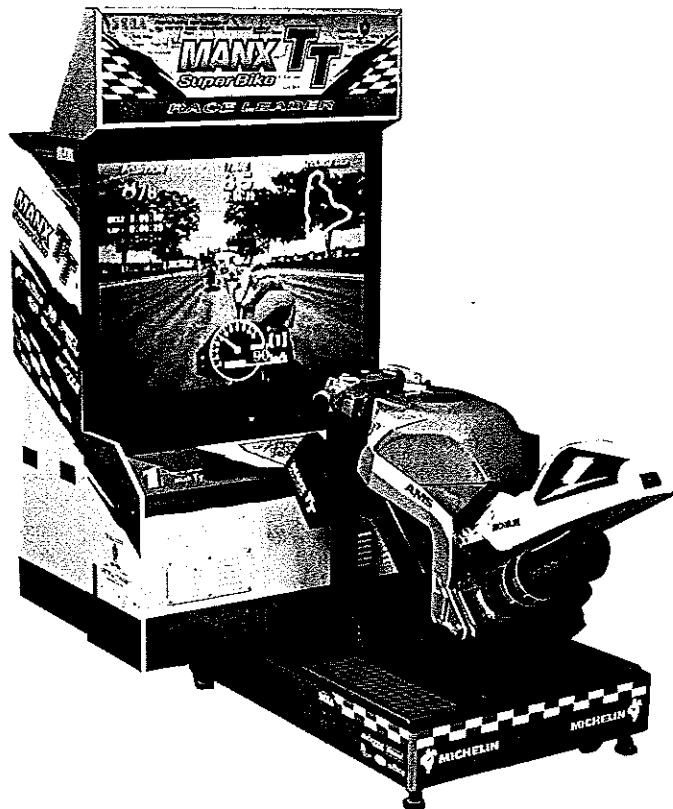

- Before using this product, read this OWNER'S MANUAL carefully to understand the contents herein stated.
- After reading this manual, be sure to keep it available nearby the product or elsewhere convenient for referring to it anytime when necessary.

SEGA ENTERPRISES, LTD.

MANUAL NO. 420 - 6207 - 01

BEFORE USING THE PRODUCT, BE SURE TO READ THE FOLLOWING:

To ensure the safe usage of the product, be sure to read the following before using the product. The following instructions are intended for the owners, operators and the personnel in charge of the operation of the product. After carefully reading and sufficiently understanding the instructions, handle the product appropriately.

Herein, explanations which require special attention are enclosed with dual lines. Depending on the potentially hazardous degrees, terms of **WARNING!**, **CAUTION!** and **IMPORTANT!** are used. SEGA is not liable whatsoever, even during the Liability period, for any injury or damage caused by the usage in the manner counter to the instructions herein stated. In order to prevent accidents, warning stickers and printed instructions are applied to the places where a potentially hazardous situation relating to the product can occur. For safety cause, be sure to comply with such warnings.



WARNING!

Indicates that mishandling the product by disregarding this warning will cause a potentially hazardous situation which can result in death or serious injury.



CAUTION!

Indicates that mishandling the product by disregarding this caution will cause a potentially hazardous situation which can result in personal injury and or material damage.



IMPORTANT!

This is cautionary information which should be complied with when handling the product. Indicates that mishandling the product by disregarding this will cause a potentially hazardous situation which might not result in personal injury but can damage the equipment, etc.

○ Be sure to turn off power before working on the machine.

To prevent electric shock, be sure to turn off power before starting the work in which the worker touches the interior of the product. If the work is to be performed in the power-on status, the Instruction Manual herein always states to that effect.

○ Be sure to ground the Earth Terminal (this, however, is not required in the case where a power cord with earth is used).

This product is equipped with the Earth Terminal. When installing the product, Connect the Earth Terminal to the "accurately grounded indoor earth terminal" by using an earth wire. Unless the product is grounded appropriately, the user can be subject to electric shock. After performing repair, etc. for the Control equipment, be sure to firmly connect the Earth Wire to the Control equipment.

○ Ensure that the Power Supply used is equipped with a Circuit Protector.

This product does not incorporate the Circuit Protector. Using a power supply which is not equipped with the Circuit Protector can cause a fire when short circuit occurs.

○ Be sure to use fuses which meet the specified rating.

○ Specification changes (removal of equipment, conversion and addition) not designated by SEGA are not allowed.

The parts of the product include warning labels for safety, covers for personal protection, etc. It is very hazardous to operate the product by removing parts and or modifying the circuits. Should doors, lids and protective parts be damaged or lost, refrain from operating the product! SEGA is not liable whatsoever for any injury and or damage caused by Specification changes (using other firm's parts, or by conversion) not designated by SEGA.

- **Ensure that the product is of appropriate Electrical Specifications.**
Before installing the product, check for Electrical Specifications. SEGA products have a nameplate on which Electrical Specifications are described. Ensure that the product is compatible with the power supply voltage and frequency requirements of the location.

- **Install and operate the product in places where appropriate lighting is available, allowing warning labels to be clearly read.**
To ensure safety for the customers, labels and printed instructions describing potentially hazardous situation are applied to places where accidents can be caused. Ensure that where the product is operated has sufficient lighting allowing the warnings to be read. If any label is peeled off, apply it again immediately.

- **When handling the Monitor, be very careful. (Applies only to the product w/ monitor).**
Some of the monitor (TV) parts are subject to high tension voltage. Even after turning off power, some portions are still subject to high tension voltage sometimes. Monitor repair and replacement should be performed only by those technical personnel who have knowledge of electricity and technical expertise.

In the case where commercially available monitors and printers are used in this product, only the contents relating to this product are explained herein. Some commercially available equipment has functions and reactions not stated in this manual. Read this manual together with the specific Instruction Manual of such equipment.

- Descriptions herein contained may be subject to improvement changes without notice.
- The contents described herein are fully prepared with due care. However, should any question arise or errors be found, please contact SEGA.

INSPECTIONS IMMEDIATELY AFTER TRANSPORTING THE PRODUCT TO THE LOCATION.

Normally, at the time of shipment, SEGA products are in a status allowing for usage immediately after transporting to the location. Nevertheless, an irregular situation may occur during transportation. Before turning on power, check the following points to ensure that the product has been transported in a satisfactory status.

- Are there any dented portions or defects (cuts, etc.) on the external surfaces of the cabinet?
- Are Casters and Leg Adjusters damaged?
- Do the power supply voltage and frequency requirements meet with those of the location?
- Are all wiring connectors correctly and securely connected? Unless connected in the correct direction, connector connections can not be made accurately. Do not insert connectors forcibly.
- Are all IC's of each IC-BD firmly inserted?
- Do power cords have cuts and dents?
- Do the fuses used meet specified rating? Is the Circuit Protector in an energized status?
- Are such units as Monitors, Control equipment, IC BD, etc. firmly secured? Are all Earth Wires connected?
- Are all accessories available?
- Can all Doors and Lids be opened with the Accessory keys? Can Doors and Lids be firmly closed?

TABLE OF CONTENTS

INTRODUCTION OF THE OWNER'S MANUAL	
1. HANDLING PRECAUTIONS	1 ~ 2
2. PREVENTION OF COUNTERFEITING AND CONVERSION ...	3
3. PRECAUTIONS CONCERNING INSTALLATION LOCATION ..	4 ~ 5
4. NAME OF PARTS	6
5. ACCESSORIES	7
6. ASSEMBLING AND PRECAUTIONS TO BE HEEDED WHEN MOVING THE MACHINE	8 ~ 18
7. OPERATION	19 ~ 22
8. EXPLANATION OF TEST AND DATA DISPLAY	23 ~ 35
8-1 SWITCH UNIT	24
8-2 TEST MODE	25
8-3 MEMORY TEST	25
8-4 INPUT TEST	26
8-5 SOUND TEST	27
8-6 C.R.T. TEST	27
8-7 GAME ASSIGNMENTS	28
8-8 COIN ASSIGNMENTS	29 ~ 31
8-9 BOOKKEEPING	32 ~ 33
8-10 BACKUP DATA CLEAR	33
8-11 OUTPUT TEST	34 ~ 35
9. HANDLE MECHANISM	36 ~ 39
9-1 ACCELERATOR/BRAKE V.R. ADJUSTMENT	37
9-2 THROTTLE/BRAKE V.R. REPLACEMENT	38
9-3 GREASING	39
9-4 SPRING REPLACEMENT	39
10. REAR BASE	40 ~ 42
10-1 VOLUME (V.R.) REPLACEMENT	40 ~ 41
10-2 INSPECTION AND REPLACEMENT OF PINION GEAR ..	42
10-3 GREASING	42
10-4 REPLACEMENT OF SAFETY RUBBER	43
11. COIN SELECTOR	44
12. PROJECTOR	45 ~ 50
12-1 CLEANING THE SCREEN	45
12-2 ADJUSTING HITACHI PROJECTORS	46 ~ 48
12-3 MITSUBISHI PROJECTOR	49 ~ 50
13. REPLACEMENT OF FLUORESCENT LAMP, AND LAMPS ...	51
14. PERIODIC INSPECTION TABLE	52
15. TROUBLESHOOTING	53 ~ 54
16. GAME BOARD	55 ~ 56
16-1 TAKING OUT THE GAME BD	55
16-2 COMPOSITION OF GAME BOARD	56
17. DESIGN RELATED PARTS	57 ~ 58
18. PARTS LIST	59 ~ 106
19. WIRE COLOR CODE TABLE	108
20. WIRING DIAGRAM	109 ~ 111

SPECIFICATIONS

Installation space	: 1,225 mm (W) × 2,520 mm (D) (48.2 in. × 99.2 in.)
Height	: 2,070 mm (81.5 in.)
Weight	: Approx. 380 kg. (837.8 lbs.)
Power, maximum current	: 952W 10.43A (AC 110V 50 Hz AREA) 851W 9.67A (AC 110V 60 Hz AREA) 884W 9.36A (AC 120V 60 Hz AREA) 990W 5.71A (AC 220V 50 Hz AREA) 1011W 5.85A (AC 220V 60 Hz AREA) 1017W 5.51A (AC 240V 50 Hz AREA) 758W 4.29A (AC 240V 60 Hz AREA)
For TAIWAN (HITACHI PROJECTION DISPLAY TYPE)	
Power, current	: 995W 10.25A (MAX.) 480W 5.65A (MIN.)
For TAIWAN (MITSUBISHI PROJECTION DISPLAY TYPE)	
Power, current	: 990W 10.25A (MAX.) 445W 5.25A (MIN.)
MONITOR	: 50 INCH PROJECTION DISPLAY

NOTE: Descriptions in this manual are subject to change without prior notice.

INTRODUCTION OF THE OWNER'S MANUAL

SEGA ENTERPRISES, LTD., supported by its high electronic technology of LSIs, microprocessors, etc. and a wealth of experience, has for more than 30 years been supplying various innovative and popular game machines to the world market. This Owner's Manual is intended to provide detailed descriptions together with all the necessary information covering the general operation of electronic assemblies, electromechanicals, servicing control, spare parts, etc. as regards MANX TT DX, a new SEGA product.

This manual is intended for those who have knowledge of electricity and technical expertise especially in ICs, CRTs, microprocessors, etc. Carefully read this manual to acquire sufficient knowledge before working on the machine. Should there be a malfunction, non-technical personnel should under no circumstances touch the interior system. Should this Owner's Manual be lost, it can be purchased by placing an order with the following or where the product was purchased from.

SEGA ENTERPRISES, INC. (U.S.A.)/CUSTOMER SERVICE
45133 Industrial Drive, Fremont, California 94538, U.S.A.
Phone : (415) 802-3100
Fax : (415) 802-1754

SEGA AMUSEMENTS EUROPE LIMITED/AMUSEMENT MACHINE SALES DIVISION
Unit 2 Industrial Estate, Leigh Close, New Malden, Surrey KT3 3NL, England
Phone : (081) 336-2256
Fax : (081) 336-1715

SEGA SOUTHERN EUROPE LIAISON OFFICE
Calle Vallellano, 19-23, 1° A, 37008-Salamanca, Spain
Phone : (923) 265893
Fax : (923) 265913

I. HANDLING PRECAUTIONS

When installing or inspecting the machine, be very careful of the following points and pay attention to ensure that the player can enjoy the game safely.

Non-compliance with the following points or inappropriate handling running counter to the cautionary matters herein stated can cause personal injury or damage to the machine.



WARNING!

- Before performing the work, be sure to turn power off. Performing the work without turning power off can cause an electric shock or short circuit.
- To avoid electric shock or short circuit, do not insert or pull out the plug quickly.
- Do not expose Power Cords and Earth Wires on the surface, (floor, passage, etc.). If exposed, the Power Cords and Earth Wires are susceptible to damage. Damaged cords and wires can cause electric shock or malfunctioning.
- To avoid causing a fire or electric shock, do not put things on or damage Power Cords.
- When or after installing the product, do not unnecessarily pull the power cord. If damaged, the power cord can cause a fire or electric shock.
- Be sure to perform grounding appropriately. Inappropriate grounding can cause an electric shock.
- Be sure to use fuses meeting specified rating. Using fuses exceeding the specified rating can cause a fire or electric shock.
- Completely make connector connections for IC BD and others. Insufficient insertion can cause an electric shock.
- To avoid causing a fire or electric shock, do not make Specification changes by removing, converting and making additions unless otherwise designated by SEGA.



IMPORTANT!

- Also, for the IC board circuit inspections, only the logic tester is allowed. The use of a multiple-purpose tester is not permitted, so be careful in this regard.
- The Projector is employed for this machine. The Projector's screen is susceptible to damage, therefore, be very careful when cleaning the screen. For details, refer to Section 10. PROJECTOR.

CONCERNING THE STICKER DISPLAY

SEGA product has Stickers describing the product manufacture No. (Serial No.) and Electrical Specifications. Also it has a Sticker describing where to contact for repair and for purchasing parts. When inquiring about or asking for repair, mention the Serial No. and Name of Machine indicated on the Sticker. The Serial No. indicates the product register. Identical machines could have different parts depending on the date of production. Also, improvements and modifications might have been made after the publication of this Manual. In order to meet the above situations, mention the Serial No. when contacting the applicable places.

CONCERNING WARNING DISPLAYS

SEGA product has warning displays on Stickers, Labels and on printed instructions adhered / attached to or incorporated in the places where a potentially hazardous situation can arise. The warning displays are intended for accident prevention for the customers and for avoiding hazardous situation relating to maintenance and servicing work. There are some portions in the Cabinet, which are subject to high tension voltage, etc. where accidents can be caused only by touching. When performing the servicing work, be very careful of the warning displays. Especially, any complex repair and replacement work not mentioned herein, should be performed by those technical personnel who have knowledge of electricity and technical expertise. For the prevention of accidents, caution any customer whose act runs counter to the warnings, as to the effect that he must stop the act.

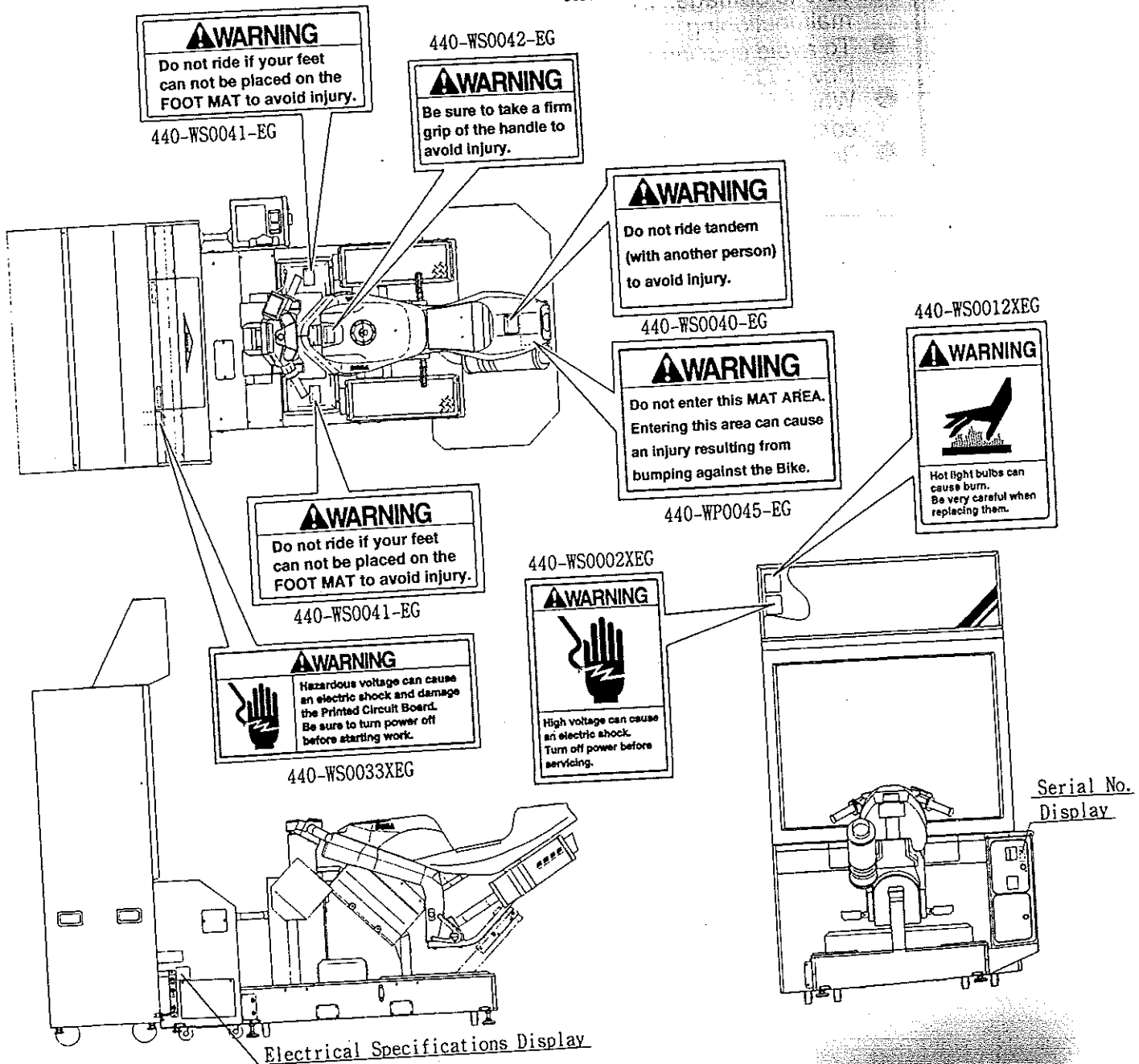

2. PREVENTION OF COUNTERFEITING AND CONVERSION

▶ LABELLING ◀

To prevent counterfeits and conversions, the following labels are put on all the SEGA products. When handling such goods, be sure to confirm the labels. They are used to prevent illegal acts such as the unauthorized copying of the products and the printed circuit boards thereof or carrying on business by manufacturing similar merchandise or by converting, selling or using such products or printed circuit boards.

ORIGINAL SEAL

The following seal is put on the machines manufactured by SEGA.



▶ COPYRIGHT NOTICE ◀

This SEGA product has the copyright notice as follows:

© SEGA 1995

This signifies that this work was disclosed in 1995 and is the property of SEGA ENTERPRISES, LTD.

3. PRECAUTIONS CONCERNING INSTALLATION LOCATION



This product is an indoor game machine. Do not install it outside. Even indoors, avoid installing in places mentioned below so as not to cause a fire, electric shock, injury and or malfunctioning.

- Places subject to rain or water leakage, or places subject to high humidity in the proximity of an indoor swimming pool and or shower, etc.
- Places subject to direct sunlight, or places subject to high temperatures in the proximity of heating units, etc.
- Places filled with inflammable gas or vicinity of highly inflammable/volatile chemicals or hazardous matter.
- Dusty places.
- Sloped surfaces
- Places subject to any type of violent impact.
- Vicinity of anti-disaster facilities such as fire exits and fire extinguishers.
- The operating (ambient) temperature range is from 5°C to 40°C. Only in the case a projector is employed, the temperature range is from 5°C to 35°C.

LIMITATIONS OF USAGE REQUIREMENTS



- Be sure to check the Electrical Specifications. Ensure that this product is compatible with the location's power supply, voltage and frequency requirements. A plate describing Electrical Specifications is attached to the product. Non-compliance with the Electric Specifications can cause a fire and electric shock.
- This product requires the Breaker and Earth Mechanisms as part of the location facilities. Using them in a manner not independent can cause a fire and electric shock.
- Ensure that the indoor wiring for the power supply is rated at 15A or higher (AC single phase 100~120V), and 7A or higher (AC 220~240V). Non-compliance with the Electrical Specifications can cause a fire and electric shock.
- Be sure to independently use the power supply equipped with the Earth Leakage Breaker. Using a power supply without the Earth Leakage Breaker can cause an outbreak of fire when earth leakage occurs.
- Putting many loads on one electrical outlet can cause generation of heat and a fire resulting from overload.
- When using an extension cord, ensure that the cord is rated at 15A or higher (AC 100~120V area) and 7A or higher (AC 220~240V area). Using a cord rated lower than the specified rating can cause a fire and electric shock.



- Note that for transporting the machine into the location's building, the minimum necessary dimensions of the opening (of doors, etc.) are 0.9m.
- For the operation of this machine, secure a minimum area of 1.3m (W) × 2.6m (D).

Electric current consumption

MAX. 10.43A (AC 110V 50 Hz)

MAX. 9.67A (AC 110V 60 Hz)

MAX. 9.36A (AC 120V 60 Hz)

MAX. 5.71A (AC 220V 50 Hz)

MAX. 5.85A (AC 220V 60 Hz)

MAX. 5.51A (AC 240V 50 Hz)

MAX. 4.29A (AC 240V 60 Hz)

MAX. 10.25A

(For TAIWAN, HITACHI projection display)

MAX. 10.25A

(For TAIWAN, MITSUBISHI projection display)

4. NAME OF PARTS

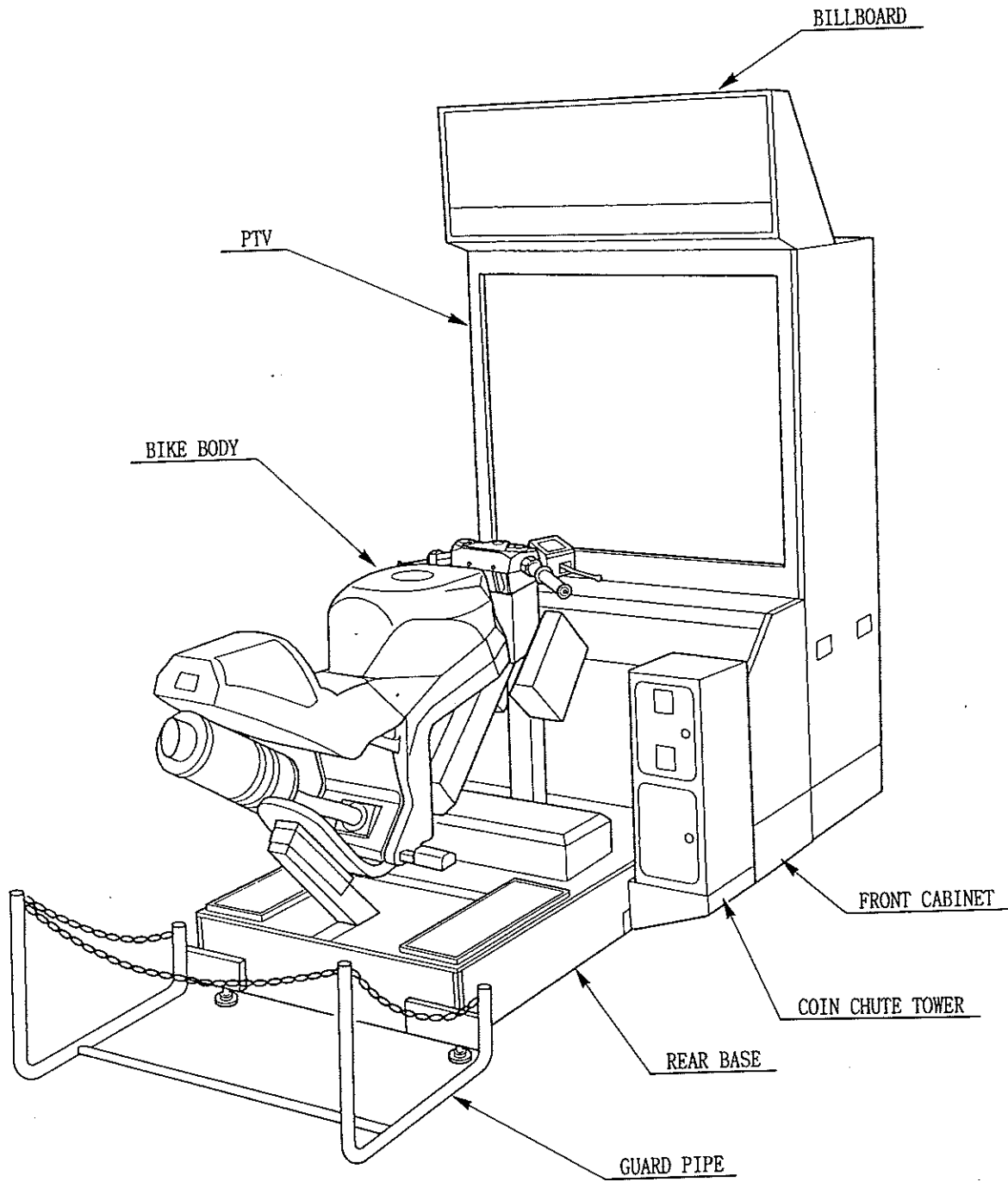

FIG. 4 OVERVIEW

TABLE 4

	Width	Length	Height (mm.)	Weight (kg.)
PTV	1,140 ×	654 ×	2,070	Approx. 135
REAR BASE	1,082 ×	1,830 ×	1,007	Approx. 167
FRONT CABI	1,140 ×	420 ×	763	Approx. 77
When assembled	1,225 ×	2,520 ×	2,070	Approx. 380

5. ACCESSORIES

When transporting the machine, make sure that the following parts are supplied.

TABLE 5 ACCESSORIES

Part No.	Qty.	DESCRIPTION	Note
200-5297	1	REMOTE CONTROLLER H (HITACHI)	Used for adjustment. See Sec. 12.
200-5410			
200-5298	1	REMOTE CONTROLLER M (MITSUBISHI)	
220-5381	2	KEY MASTER FOR 220-5380	For opening/closing the doors
	2	KEY	For the CASHBOX DOOR
220-5373	1	VOL CONT B-5K OHM	For spare, refer to Section 9.
220-5484		VOL CONT B-5K OHM	
420-6207-01	1	OWNERS MANUAL MANX TT DX ENG	
421-9008	1	STICKER TTR No.1~8	For communications play.
421-9014		STICKER FRONT No.1~8	
032-000416	3	WING BLT M4×16	For maintenance, refer to Section 10.
514-5036-7000	1	FUSE 6.4 ϕ × 30 7000mA 125V	For spare, refer to Section 15.
509-0161	1	PUSH BUTTON SWITCH 1T YELLOW W/LAMP	For spare, refer to Section 9.
600-6664-02	1	WIRE HARN EARTH W/LUG M6	Used for installation, see Sec 6.

6. ASSEMBLING AND PRECAUTIONS TO BE HEEDED WHEN MOVING THE MACHINE



- Perform the assembly work by following the procedure herein stated. Failing to comply with the instructions can cause an electric shock.
- Assembling should be performed as per this manual. Since this is a complex machine, erroneous assembling can cause an electric shock or damage to the machine resulting in not functioning as per specified performance.
- When assembling, be sure to perform the work by plural persons. Depending on the assembly work, there are some cases in which performing the work by a single person can cause personal injury or parts damage.

When carrying out the assembly work, follow the procedure in the following 5-item sequence:

- 1 ASSEMBLING THE PTV
- 2 ASSEMBLING THE CABINET
- 3 INSTALLING THE COIN CHUTE TOWER
- 4 SECURING IN PLACE (LEG ADJUSTER ADJUSTMENT)
- 5 POWER SUPPLY, AND EARTH CONNECTION
- 6 ASSEMBLY CHECK

The Master Key and Cashbox Door Key (accessories) are required for assembly work, in addition to the "plus" (Phillips type) screwdriver, wrench (for M16 hexagon bolts) and socket wrench (for M8 hexagon bolts).

1 ASSEMBLING THE PTV

- ① By using the specified screws, secure the 2 Mask Holders to the Projection Display ceiling.
- ② Insert the TV Mask from the underside as shown and secure with a total of 6 screws in the manner to sandwich the LOCK BRACKET as shown.
- ③ Secure the two Guide Brackets to the front of the Projection Display in the correct installation direction shown, by using 2 screws for each Bracket.
- ④ Insert the Billboard's 2 Connectors into the Terminal Board of Projection Display ceiling.
- ⑤ Insert the Billboard from the front as shown and secure with 2 screws.

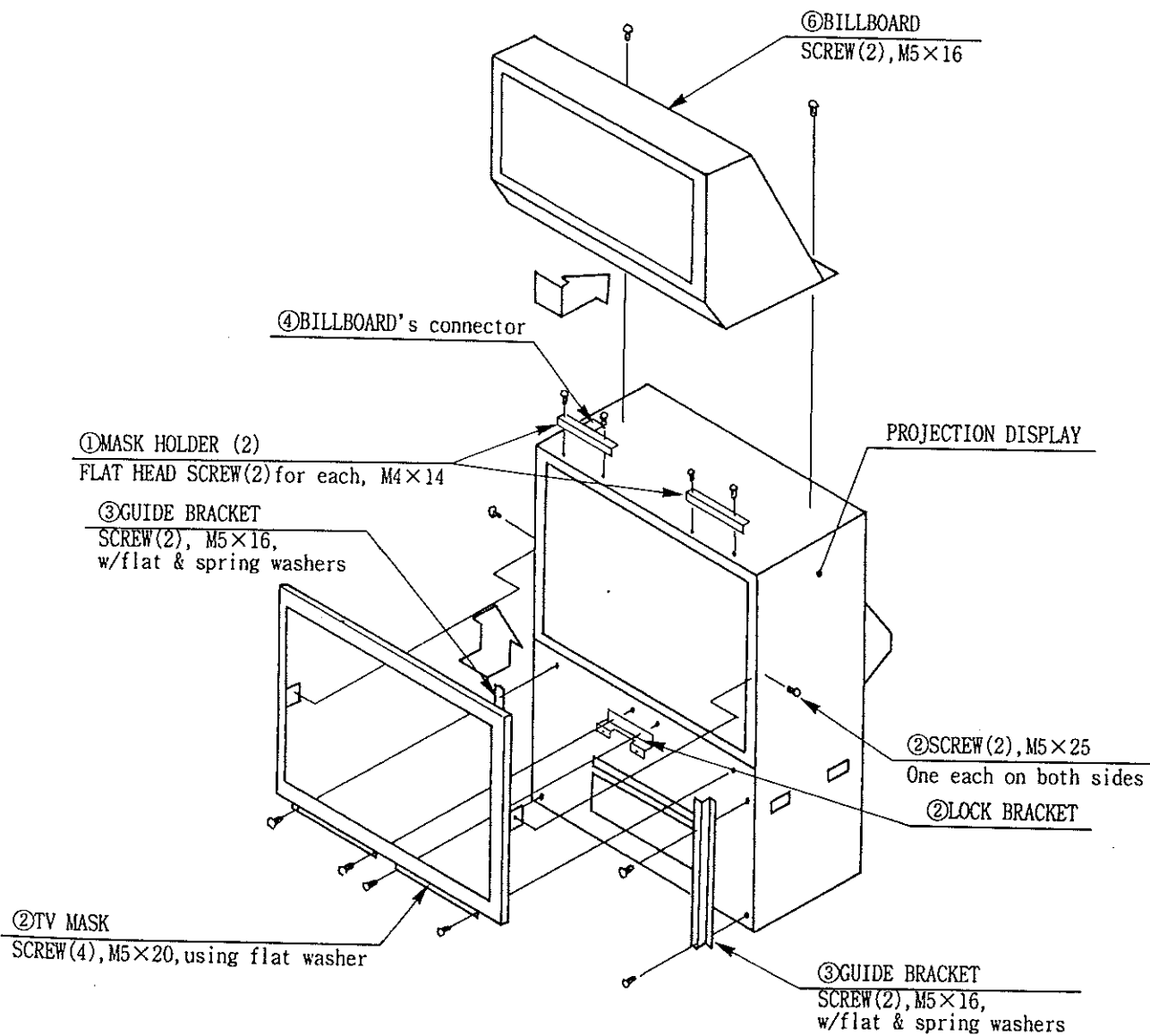

FIG. 6. 1

2

ASSEMBLING THE CABINET



During assembling work, the cabinet is moved. When assembling, ensure that casters of each cabinet are in contact with the floor.

- ① Secure the two L type Brackets to the Rear Base by using 2 hexagon bolts (black) for each Bracket.
- ② Insert the Rear Base's square pipes into the Front Cabinet's square holes. At this time pay careful attention so that the Front Cabinet's wirings are not caught.
- ③ Remove the 2 Truss Screws to open the Hole Lid on the upper part face of the Rear Base shown.
- ④ Connect a total of 6 Connectors inside the Rear Base.
- ⑤ By using the 4 Hexagon Bolts (black), securely fasten the L type Brackets secured as per ① above.
- ⑥ Connect Front Cabinet wirings to the Connector Panel inside the previously assembled PTV. At this time make sure that the wire color (red, green, blue and the remaining color) corresponds with the applicable symbol of the Connector Panel's Display (R. G. B. and SYNC terminals).

Also, note that the connector's insertion angle is predetermined. The connector can be damaged if forcibly inserted in an incorrect direction. Therefore, ascertain the correct direction before insertion. After insertion, turn the connector ring clockwise to lock the connection.

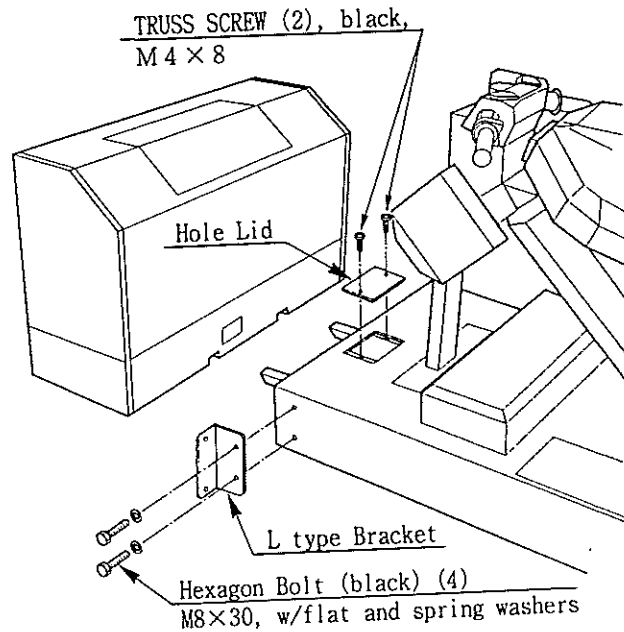
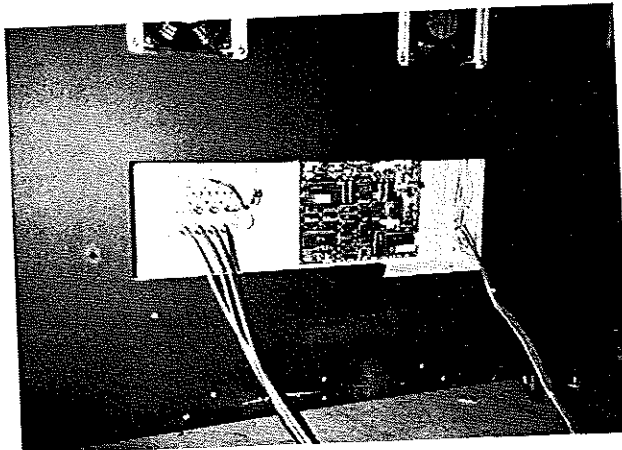
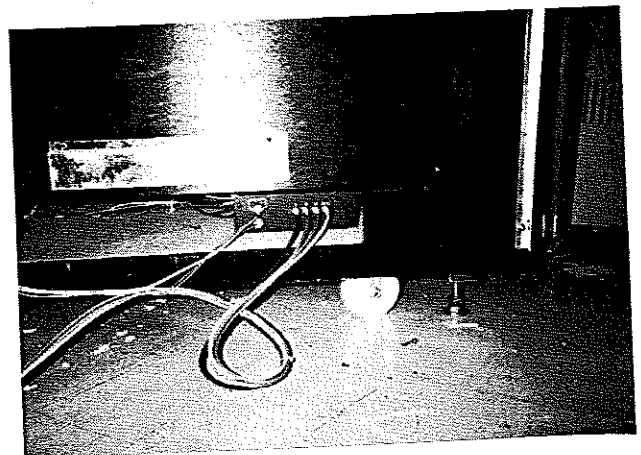

FIG. 6. 2 a



Front Cabinet side



PTV side

FIG. 6. 2 b

- ⑦ Fit the Cabinet along the PTV's Guide Bracket.
- ⑧ Open the Front Cabinet's Service Lid by taking out the 2 screws and using the Master Key, and secure the PTV and the Cabinet with 2 Truss Screws.
- ⑨ Reinstall the previously removed Hole Lid and Service Lid.

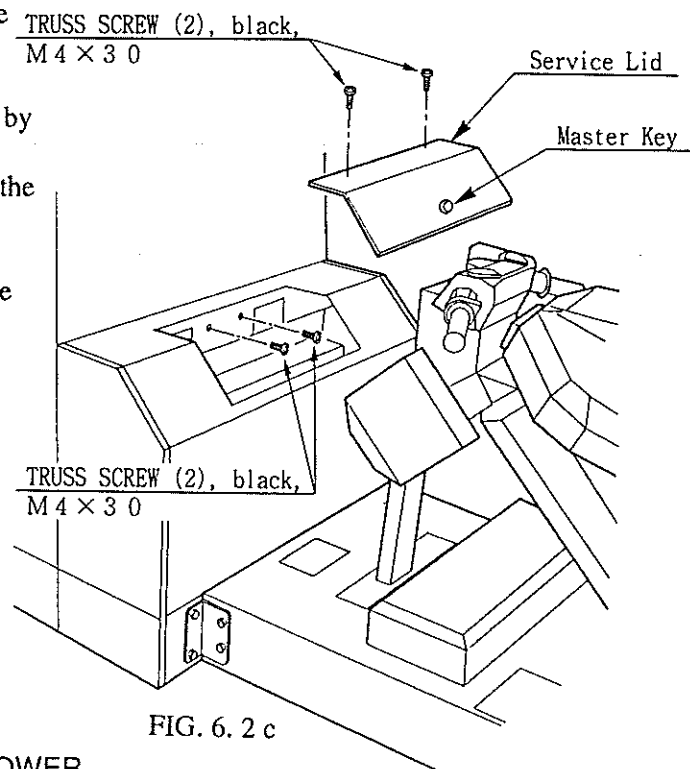

FIG. 6. 2 c

3

INSTALLING THE COIN CHUTE TOWER

- ① By using the 4 Hexagon Bolts (black), secure the Tower Base to the side of the Rear Base as shown.
- ② Connect the connectors which come from the Coin Chute Tower's Base with connectors inside the Tower Base, and fit the Coin Chute Tower to the Tower Base.
- ③ By taking off the 2 Truss Screws, remove the Lid for Optic Fiber from the side of the Front Cabinet.
- ④ Secure the Tower Support with the 2 Hexagon nuts from the inside of the Front Cabinet.
- ⑤ Open both of the upper and lower doors of the Coin Chute Tower and secure the Coin Chute Tower with 4 Hexagon Bolts.

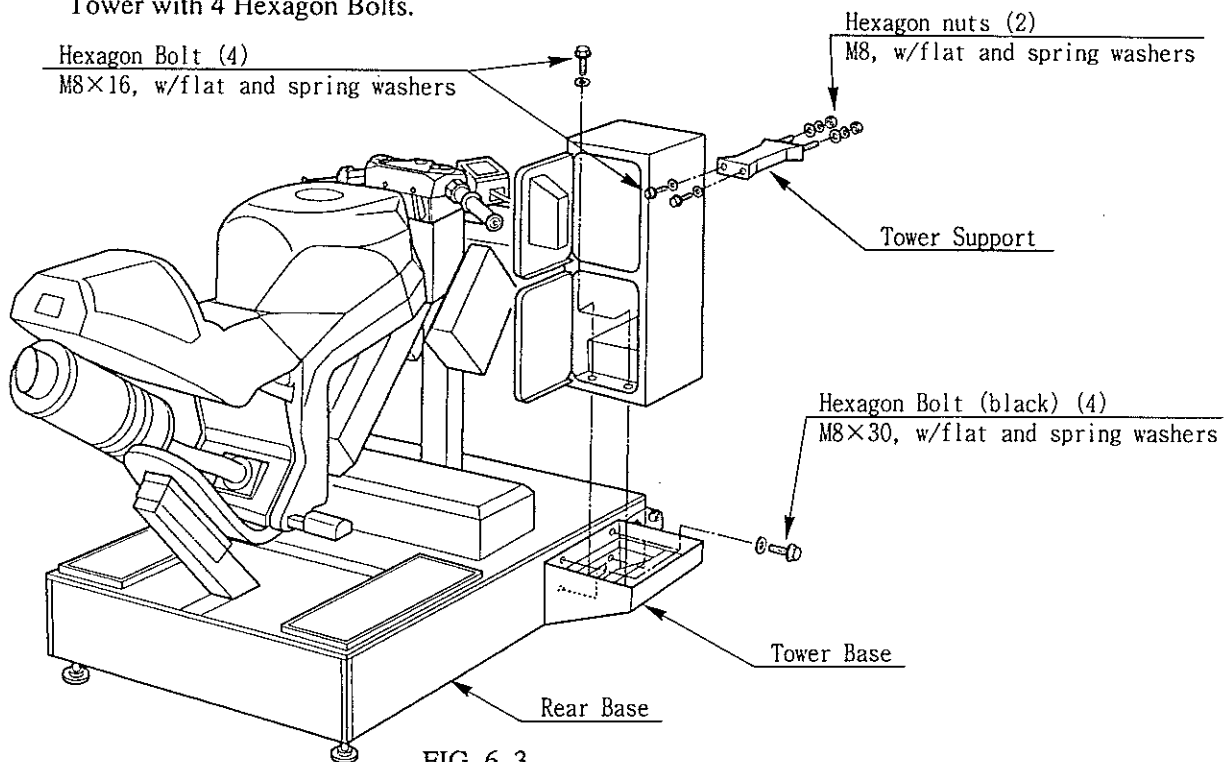

FIG. 6. 3

4 SECURING IN PLACE (LEG ADJUSTER ADJUSTMENT)



Make sure that all of the leg adjusters are in contact with the floor. If they are not, the cabinet may move causing an accident.

This machine has 12 casters (4 for the front cabinet, 4 for the rear base and 4 for the PTV) and 10 leg adjusters (2 for the front cabinet, 4 for the rear base and 4 for the PTV). When the installation position is determined, cause the leg adjusters to come into contact with the floor directly, make adjustments in a manner so that the casters will be raised approximately 5mm. from the floor and make sure that the machine position is level.

- ① Move the machine to the installation position. When installing the machine against or close to a wall, be sure to secure a passage space to enable the player to take a ride in the machine.
- ② Cause all of the leg adjusters to make contact with the floor. By using a wrench, make adjustments in the height of the leg adjusters to ensure that the machine's position is level.
- ③ When causing the Leg Adjusters to come into contact with the surface, make sure the accessory Safety Mat is laid in the manner allowing the 2 Leg Adjusters of the rear part of the Rear Base to be caught by the 2 corresponding mat holes.
- ④ After making adjustments, fasten the leg adjuster nut upward and secure the height of the leg adjuster.

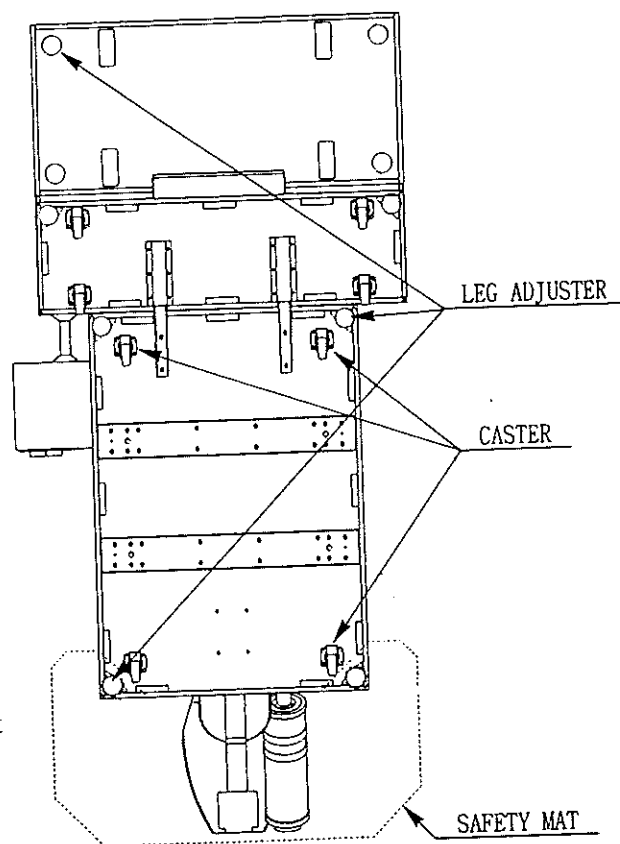

FIG. 6.4 a BOTTOM VIEW

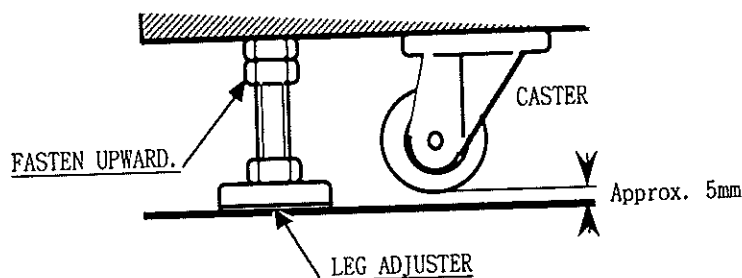
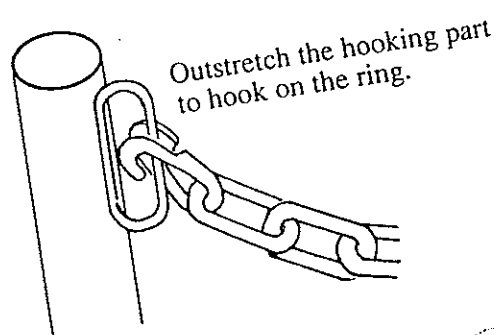
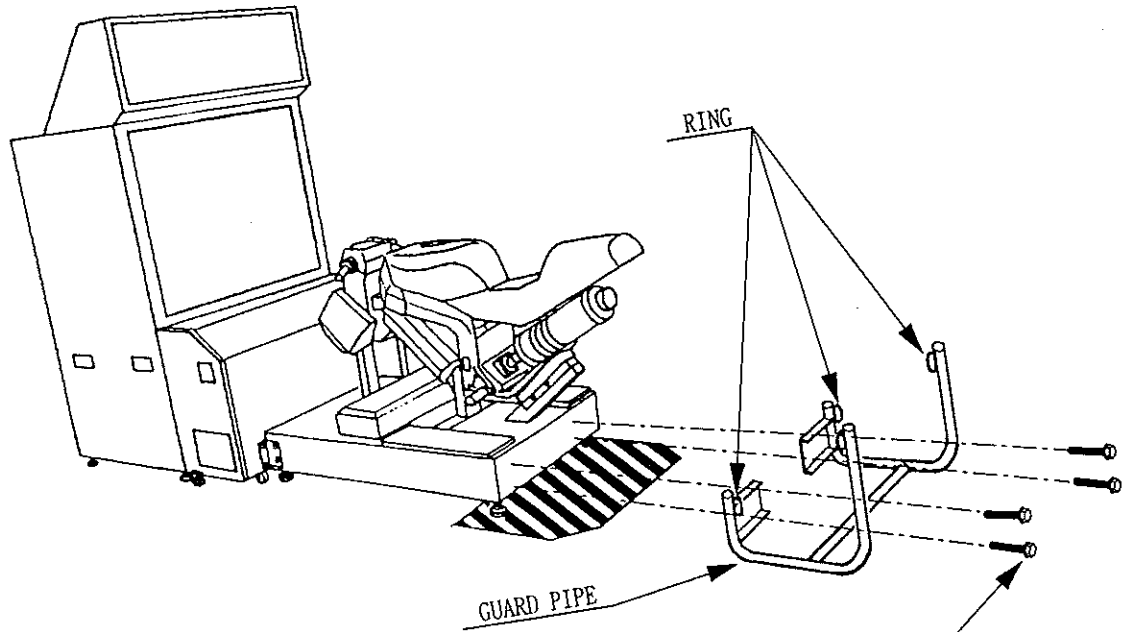
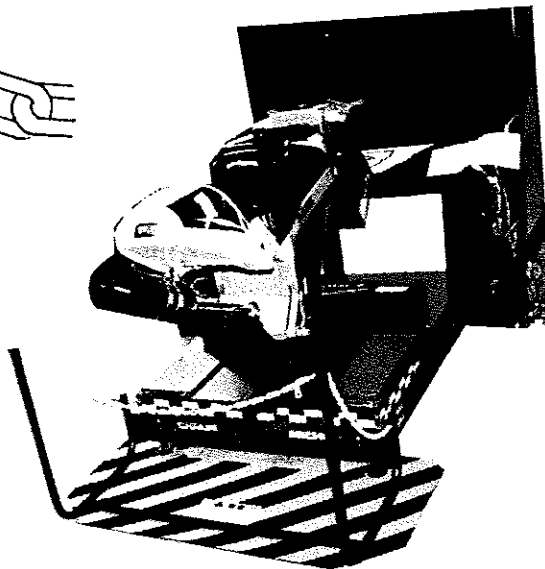

FIG. 6.4 b LEG ADJUSTER

- ⑤ Install the Guard Pipe to the Rear Base and secure with 4 Hexagon Bolts.
- ⑥ Hook the chain on the Guard Pipe Rings. Two parts (hooks) other than the both ends of the chain can be used to hook the chain on the rings.



Hexagon Bolt (black) (4)
M8×30, w/flat and spring washers



5 POWER SUPPLY, AND EARTH CONNECTION



WARNING!

- Be sure to independently use the power supply socket outlet equipped with an Earth Leakage Breaker. Using a power supply without an Earth Leakage Breaker can cause a fire when the leakage occurs.
- Ensure that the "accurately grounded indoor earth terminal" and the earth wire cable are available. This product is equipped with the earth terminal. Connect the earth terminal and the indoor earth terminal with the prepared cable. If the grounding work is not performed appropriately, customers can be subjected to an electric shock, and the product's functioning may not be stable.
- Ensure that the power cord and earth wire are not exposed on the surface (passage, etc.). If exposed, they can be caught and are susceptible to damage. If damaged, the cord and wire can cause an electric shock or short circuit. Ensure that the wiring position is not in the customer's passage way or the wiring has protective covering.

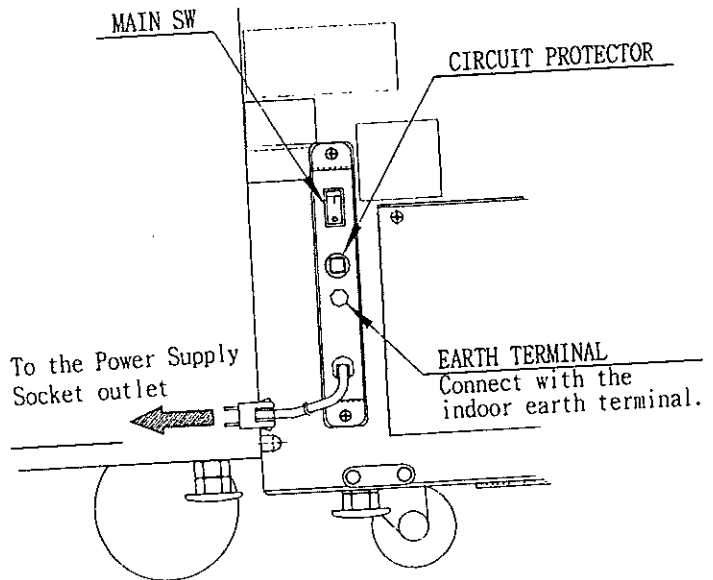

FIG. 6.5 a AC unit

- ① The AC Unit is mounted on the left side of the Cabinet. The AC Unit incorporates the Main SW, earth terminal and power cord.
- ② Ensure that the Main SW is OFF.
- ③ Connect one end of the earth wire to the AC Unit earth terminal, and the other end to the indoor earth terminal. The AC Unit earth terminal has a Bolt and Nut combination. Take off the Nut, pass the earth wire through the Bolt, and fasten the Nut.

Connect the Earth Wire to the Earth Terminal.

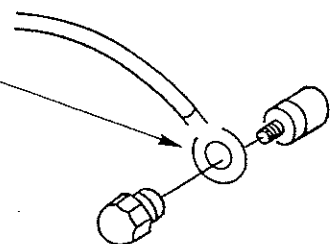

FIG. 6.5 b Earth Wire Connection

- ④ Firmly insert the power plug into the socket outlet.
- ⑤ Perform wiring for the Power Cord and Earth Wire. Install protective covering for the Power Cord and Earth Wire.

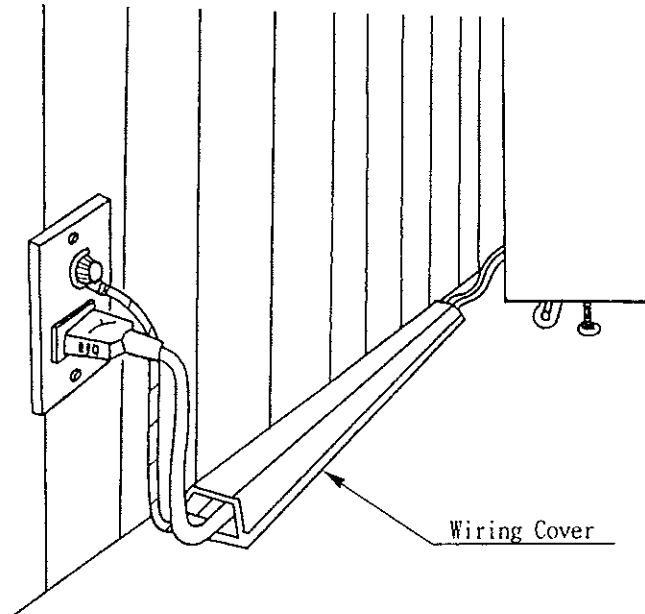

FIG. 6. 5 c Connecting Power Cord and Earth Wire

CAUTIONS TO BE HEDED WHEN TURNING POWER ON



CAUTION!

First make sure that no one is in the periphery of the bike body, and turn the Main SW on. When the power is turned on, the bike body motion starts automatically. The presence of a person(s) in the periphery of the bike can cause an accident.

Turning the AC Unit's Main SW on will cause the machine to start the POWER ON check automatically. In the POWER ON check, the bike body banks left and right, then returns to the centering position and stops. During this check, do not touch the bike body. If you do, the body reaction (at the time of a course-out or crashing) can not be obtained correctly. The Advertise mode is displayed at the same time the checking is finished. An ERROR display is indicated if an irregularity is found in the POWER ON check. In case of an irregular reaction during game, turn off power and turn it back on again to finish the POWER ON check.

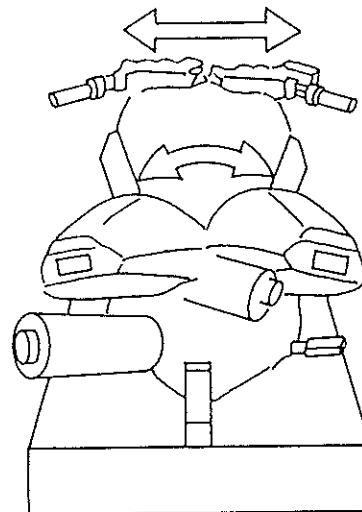

FIG. 6. 5 d

Do not touch the bike body till the Advertise mode is displayed.

6 ASSEMBLY CHECK

In the TEST MODE, ascertain that the assembly has been made correctly and IC BD. is satisfactory (refer to Section 8).

In the test mode, perform the following test:

(1) MEMORY TEST

```

MEMORY TEST
IC** GOOD   IC** GOOD   IC** GOOD
IC** GOOD   IC** GOOD   IC** GOOD
IC** GOOD   IC** GOOD   IC** GOOD
IC** GOOD   IC** GOOD   IC** GOOD

IC** GOOD   IC** GOOD   IC** GOOD
IC** GOOD   IC** GOOD   IC** GOOD
IC** GOOD   IC** GOOD   IC** GOOD

PUSH TEST BUTTON TO EXIT
  
```

Selecting the MEMORY TEST on the test mode menu screen causes the on-board memory to be tested automatically. The game board is satisfactory if the display beside each IC No. shows GOOD.

(2) INPUT TEST

```

INPUT TEST
THROTTLE : MIN MAX MID
BRAKE    : **H (**H) (**H)
BANK     : **H (**H) (**H) (**H)

SHIFT UP : OFF
SHIFT DOWN : OFF
START /VR : OFF

COIN CHUTE #1 : OFF
COIN CHUTE #2 : OFF
SERVICE      : OFF
TEST         : OFF

PUSH TEST BUTTON TO EXIT
  
```

Selecting the INPUT TEST on the test mode menu screen causes the screen (on which each switch and V. R. are tested) to be displayed. Press each switch. For the coin switch test, insert a coin from the coin inlet with the coin chute door open. If the display beside each switch indicates "ON," the switch and wiring connections are satisfactory. Check the display of each V.R. value. If the V. R. is malfunctioning, refer to Sections 9 & 10.

(3) SOUND TEST

```

SOUND TEST

VOICE      :
EFFECT     :
EFFECT_M1  :
BRAKE_M1   :
ENGINE_M1  :
ENGINE     :
B. G. M.   :
>EXIT

SELECT BY SERVICE BUTTON
AND PUSH TEST BUTTON
  
```

In the TEST mode, selecting SOUND TEST causes the screen (on which sound related BD and wiring connections are tested) to be displayed. Be sure to check if the sound is satisfactorily emitted from each speaker and the sound volume is appropriate.

(4) C.R.T. TEST

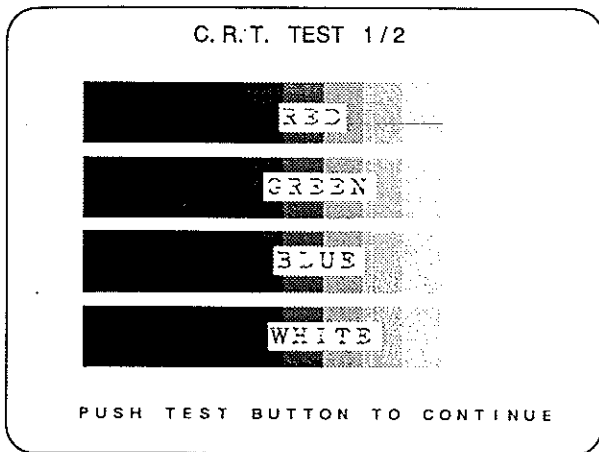

In the TEST mode menu, selecting C.R.T. TEST allows the screen (on which the projector is tested) to be displayed. Although the projector adjustments have been made at the time of shipment from the factory, color deviation, etc., may occur due to the effect caused by geomagnetism, the location building's steel frames and other game machines in the periphery. By watching the test mode screen, make judgment as to whether an adjustment is needed. If it is necessary, adjust the projector by referring to Section 12.

(5) OUTPUT TEST

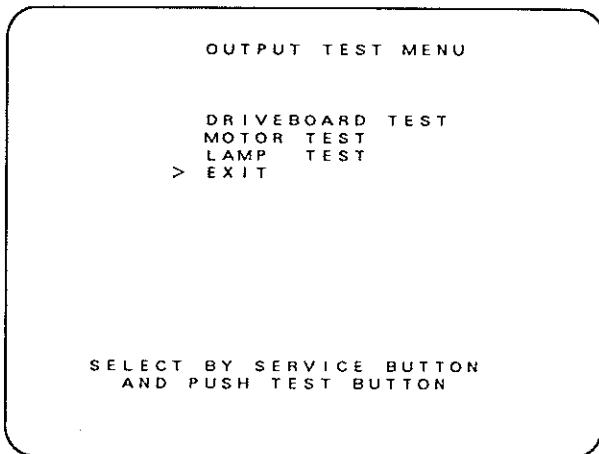

In the output test mode, carry out lamp test to ascertain that each lamp lights up satisfactorily.

Perform the above inspections also at the time of monthly inspection.

PRECAUTIONS TO BE HEEDED WHEN MOVING THE MACHINE



- When moving the machine, be sure to pull out the plug from the power supply. Moving the machine with the plug as is inserted can cause the power cord to be damaged, resulting in a fire and or electric shock.
- When moving the machine on the floor, retract the Leg Adjusters and ensure that Casters make contact with the floor. During transportation, pay careful attention so that Casters do not tread power cords and earth wires. Damaging the power cords can cause an electric shock and or short circuit.
- When moving the PTV, do not push it from the rear side. Push it from sideways. Pushing the PTV from the rear side can have the PTV fall down, causing personal injury etc. In case the floor has slanted surfaces or step-like differences, be sure to move the machine by 2 or more persons.



When moving the machine on the floor with slanted surfaces or step-like differences, ensure that the PTV, Front Cabinet and Rear Base are separated. Lifting the Cabinet with those items as is joined can cause the joint portions to be damaged.

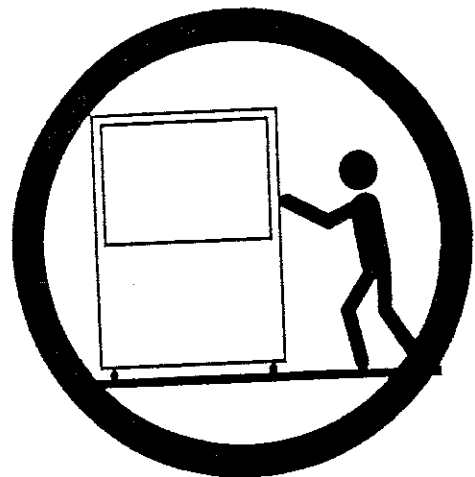

Do not push the PTV from the rear side. Pushing the PTV from the rear side can cause the PTV to fall down. Push it from the side.

7. OPERATION

PRECAUTIONS TO BE HEEDED BEFORE STARTING THE OPERATION



In order to avoid accidents, check the following before starting the operation:

- To prevent accidents, provide sufficient space for machine installation considering potentially crowded situation. Depending on the player's operation, the bike body banks left and right. If the installation space is limited, the bike can come into contact with and hit customers causing an accident or trouble.

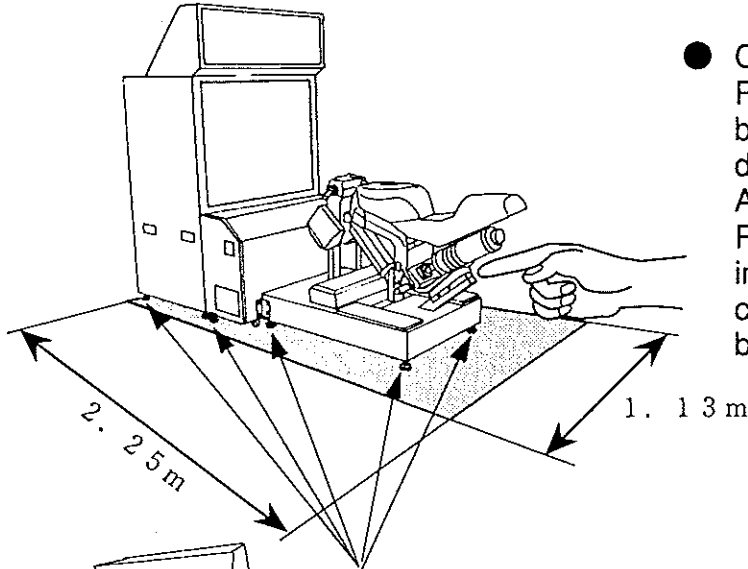

- Check the Safety Rubber of the bike body's rear part for any damage or omission. An irregular Safety Rubber can cause injury such as the customer's finger(s) being caught.

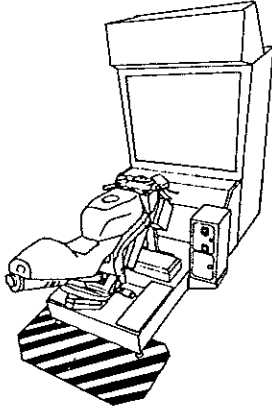

- Check if all of the Leg Adjusters are in contact with the surface. If they are not, the Cabinet can move, causing an accident.
- Check if the Safety Mat is incorrectly positioned or damaged. If there is an irregularity of the Safety Mat, customers other than the player can come close to the cabinet during play, causing an accident.

CAUTIONS TO BE HEEDED DURING OPERATION



In order to avoid accidents, check the following during operation:

- The player whose feet can not be placed on the base could fall down causing an accident. To avoid an accident, instruct persons of short stature to refrain from playing the game.

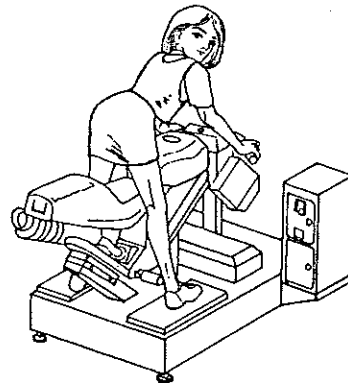



- Instruct those who wear high-heeled shoes to refrain from playing the game by explaining that playing game with high-heeled shoes is very likely to cause potentially hazardous situation.



- To avoid injury and parts damage, instruct not to ride tandem (with another person).

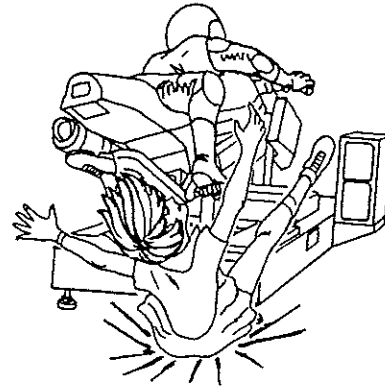

- Instruct the player to take a firm grip of the handle during play. This machine reacts as per the game contents. At the time of course out and crashing, the bike body is subject to swinging compulsorily. To avoid injury, instruct the players to refrain from single-handed taking grip of the handle (which is very likely to cause potentially hazardous situation, should he attempt to do so).

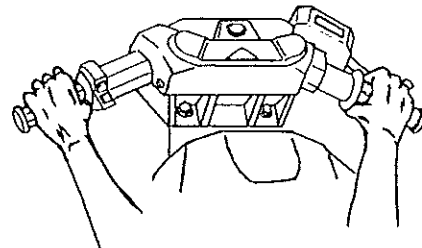

- To avoid injury resulting from coming into contact with the player or the bike body, keep persons other than the player away from the Rear Base.

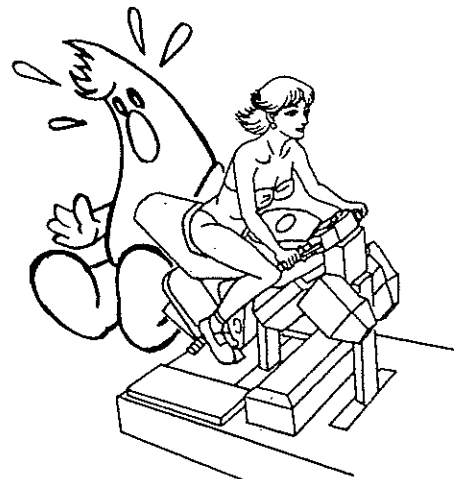

- To avoid injury, and damage to parts and items, instruct the player not to place things on the base.

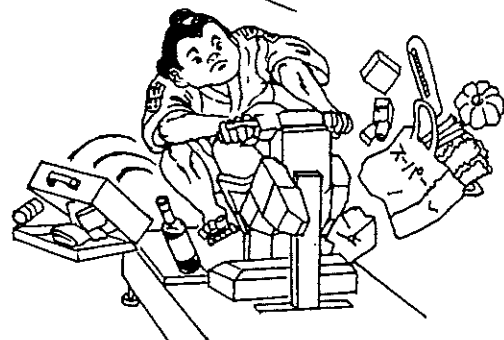

- Caution persons under the influence of liquor to refrain from playing the game.

HOW TO PLAY

Herein, explanations are given for using the machine independently. In case of interactive Communication play, how to start, etc. differ from the following descriptions.

- ① Ride the bike by striding the bike body. The bike body is locked and would not move, except for game time.
- ② As seen from the position facing the Projector screen, the Coin Chute Tower is on the right-hand side. Insert a coin(s). Inserting one play worth coin(s) allows how-to-operate explanation screen to appear. In the how-to-operate explanation mode, credit display will not be indicated. Up to 9 credits can be counted at one time. Coins inserted after counting 9 credits will neither be counted nor returned.
- ③ When Time Count in the how-to-operate explanation mode becomes zero, or when the Start button is pressed and the explanation screen is skipped, bike body locking will be cancelled and the course selection screen appears.
- ④ The isle where the courses are, appears in the central portion of the screen, with explanations given regarding the easy course on the lower left part of the screen and the technical course on the lower right portion. Incline the bike to select the course and press the START button to make the selection effective (Note 1).

At this time, press the Start button while applying the brake or turn the Throttle towards you while applying brake to enter the Time Trial Mode (Note 2).

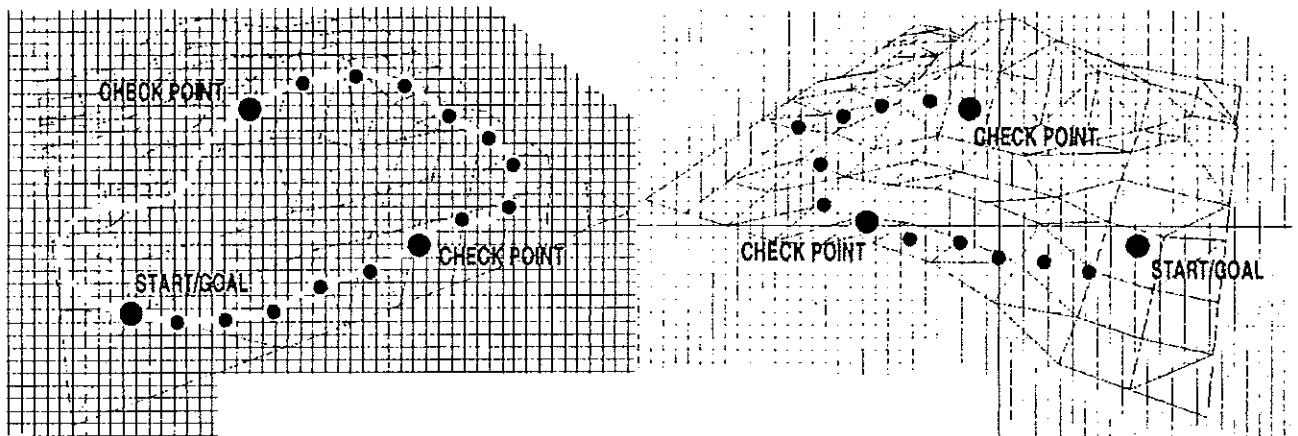

LAXEY COAST

T. T. COURSE

- ⑤ Transmission select screen appears. Choose AUTO or MANUAL by inclining the bike as when selecting the course and press the START button to make the selection effective. At the time of transmission selection, BGM (background music) can be chosen by using the SHIFT button (SHIFT-UP and SHIFT-DOWN).

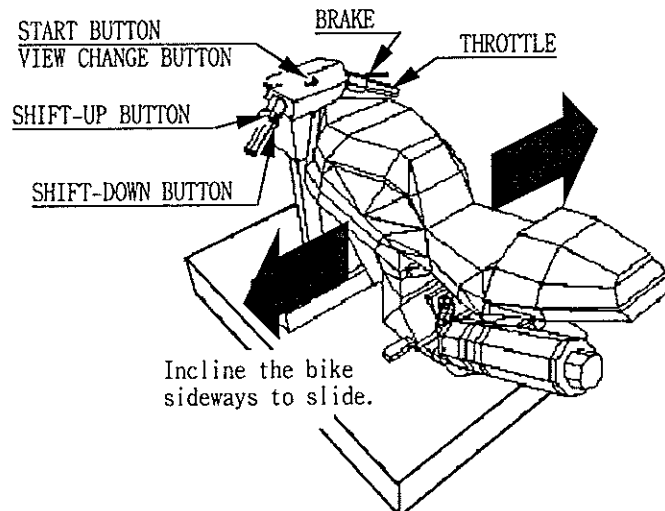

⑥ After the transmission is selected, the game starts.

⑦ In the game mode, the upper left portion of the screen displays the player's position, lap time and No. of laps. The upper center of the screen indicates time limit and the comprehensive lap time. The upper right portion of the screen shows the course map. The lower part of the screen displays tachometer, speedometer and shift (indicated in the central portion of the screen in the Rider's Eye perspective and on the lower right portion in the Rear View perspective).
Note 3.

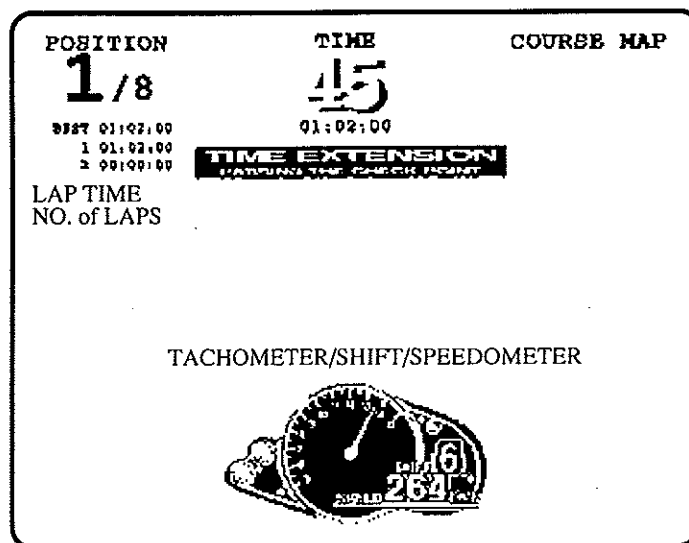

GAME MODE

⑧ When the game starts, time limit countdown starts. Passing a checkpoint before the remaining time becomes zero allows the player to continue game by adding the remaining time of the previous section to the time limit covering up to the next checkpoint. Failing to pass a checkpoint results in GAME OVER.

⑨ Both in the easy and technical courses, finishing 2 laps ends the game.

⑩ The good players can register his name. Incline the bike to choose characters and press the START button to make the selection effective. The name entered for DEMO mode will be displayed.

⑪ After finishing the game, the motor functions to return the bike body to the centering position, and the bike is locked and secured (Note 5).

⑫ After one game, if any credits allowing for play still remain, the how-to-operate explanation screen will appear.

Note 1 Turning the Throttle towards you and then returning it to the original position can also make the selection effective. Turning the Throttle towards you and leaving it intact without returning it to the original position is ineffective.

Note 2 In the game setting mode, the game mode is set to Race Mode or Time Trial Mode (see 8-7). When set to Race Mode, you can play in the Time Trial Mode by using the aforementioned procedure.

Note 3 During play, pressing the START button alternates RIDER'S EYE and REAR VIEW perspectives.

Note 4 Lap frequency setting can be changed.

Note 5 During game play, the bike reacts of itself, depending on the surface condition and the player's operation. Also, engine sound is emitted from the woofer speaker in the muffler in the manner meeting the acceleration status.

ADVICE ON PLAY

- Choose AUTO when you are not familiar with the game.
- When passing corners, try to incline yourself and not the bike.
- In the Technical Course, memorize the course map and try to find the braking points for each course.
- For shift change, engine sounds and vibration should be taken into consideration apart from the tachometer indicator's movements.

8. EXPLANATION OF TEST AND DATA DISPLAY

By operating the switch unit, periodically perform the tests and data check. When installing the machine initially or collecting cash, or when the machine does not function correctly, perform checking in accordance with the explanations given in this section. The following shows tests and modes that should be utilized as applicable.



IMPORTANT!

CAUTIONS TO BE HEEDED WHEN USING THE TEST MODE:

In the case where multiple units are linked for communication play, exiting from the test mode causes the unit to perform the network check automatically. During this time, all of the linked units will not allow the game to be played in normal status. Therefore, be sure not to enter the test mode if any one of the units is in play. On the other hand, if even one unit is in the test mode, make sure that other machines are not in play.

TABLE 8 EXPLANATION OF TEST MODE

ITEMS	DESCRIPTION	REFERENCE SECTIONS
INSTALLATION OF MACHINE	When the machine is installed, perform the following: 1. Check to see that each setting is as per standard setting made at the time of shipment. 2. In the INPUT TEST mode, check each SW and VR. 3. In the OUTPUT TEST mode, check each of lamps. 4. In the SELF-TEST mode, check ICs on the IC Board.	8-7, 8-8 8-4 8-1 1 8-3
MEMORY	Choose MEMORY TEST in the MENU mode to allow the MEMORY test to be performed. In this test, PROGRAM RAMs, ROMs, and ICs on the IC Board are checked.	8-3
PERIODIC SERVICING	Periodically perform the following: 1. MEMORY TEST 2. Ascertain each setting. 3. In the INPUT TEST mode, test the CONTROL device 4. In the OUTPUT TEST mode, check each of lamps.	8-3 8-7, 8-8 8-4 8-1 1
CONTROL SYSTEM	1. In the INPUT TEST mode, check each SW and VR. 2. Adjust or replace each SW and VR. 3. If the problem can not be solved yet, check the CONTROL's moves.	8-4 9, 1 0
MONITOR	In the MONITOR ADJUSTMENT mode, check to see if the PROJECTOR adjustment is appropriately made.	8-6 1 2
IC BOARD	1. MEMORY TEST 2. In the SOUND TEST mode, check the sound related ROMs.	8-3 8-5
DATA CHECK	Check such data as game play time and histogram to adjust the difficulty level, etc..	8-9

8-1 SWITCH UNIT



Do not touch places other than those specified. Touching places not specified can cause an electric shock or short circuit accident.

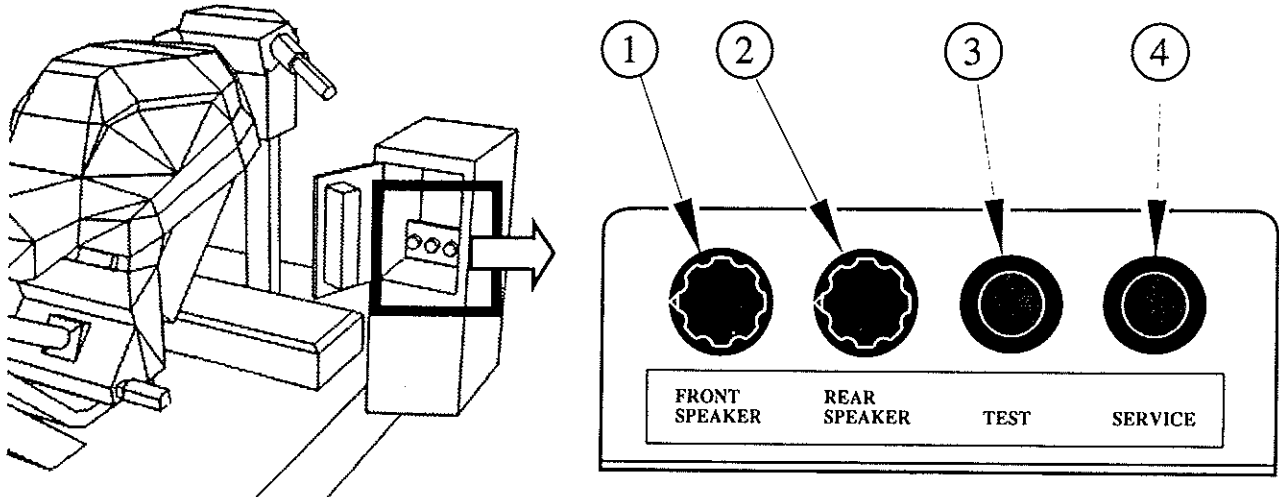

FIG. 8.1 a SWITCH UNIT

Open the coin chute door, and the switch unit shown will appear. The functioning of each SW is as follows:

- ① **SPEAKER VOL. FRONT SPEAKER** : Adjusts the sound volume of the Front Cabinet's left/right Speakers.
- ② **SPEAKER VOL. REAR SPEAKER** : Adjusts the sound volume of the bike body's left/right Speakers and that of the Speaker in the Muffler.
- ③ **TEST BUTTON TEST** : For the handling of the test button, refer to the following pages.
- ④ **SERVICE BUTTON SERVICE** : Gives credits without registering on the coin meter.

The Handle Mecha's buttons and switches are also used in the test mode. For each functioning, refer to the next page onward.

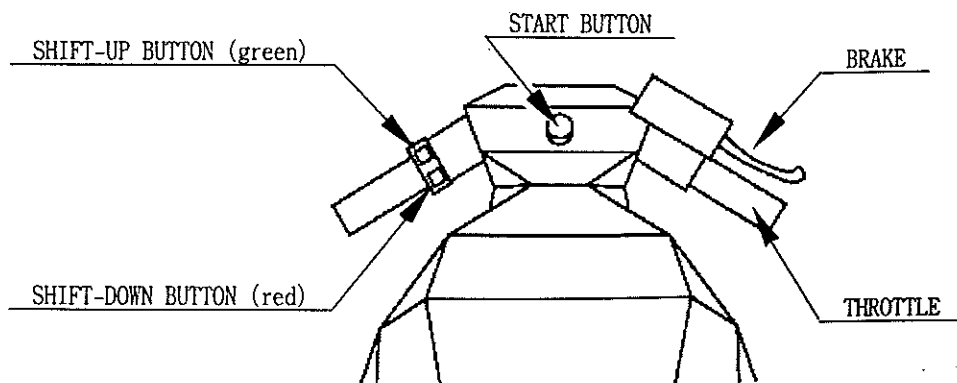

FIG. 8.1 b HANDLE MECHA

8-2 TEST MODE

The Test Menu allows the functioning of each part of the Cabinet to be checked, the monitor to be adjusted, and the coins and game related various settings to be performed.



In the Test Mode, pay careful attention to bike movements. Entering the Test Mode unlocks the bike body, and returning to the Game Mode performs centering and securely locks the bike body. Pressing the TEST button while the player is on the bike can move the bike causing injury.

- Pressing the TEST button displays the test menu (FIG. 8.2) and at the same time, unlocks the bike body.
- Press the SERVICE BUTTON till the pointer ">" is moved to the desired item to make a selection.

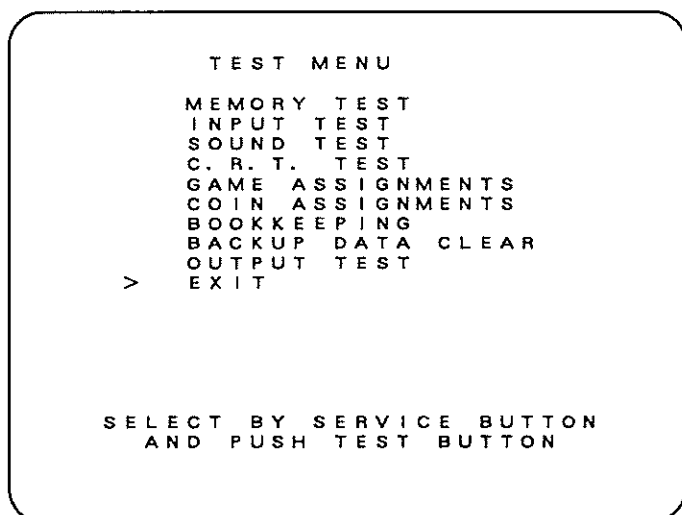

FIG. 8.2 TEST MENU

- Bring the pointer ">" to the desired item and press either the TEST BUTTON or START BUTTON to cause the selected item's test to start.
- Choosing EXIT and pressing the TEST button or the START button will end the Test Mode, causing the Game Mode to return. At the same time, bike body centering is performed, and after centering, the bike is locked.

8-3 MEMORY TEST

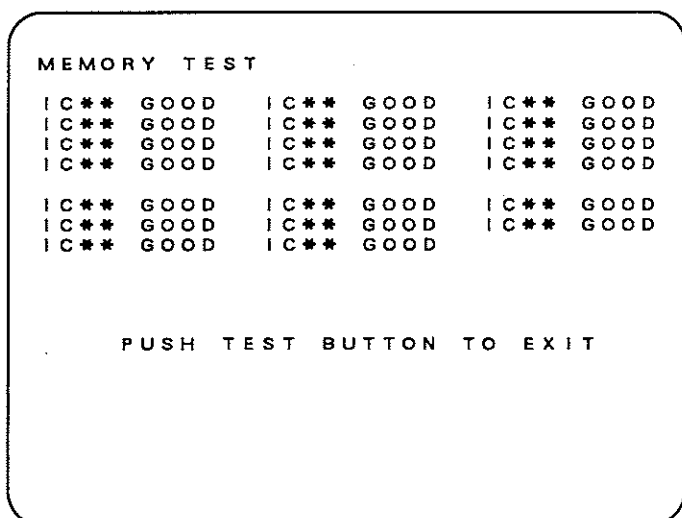

FIG. 8.3 MEMORY TEST

The MEMORY TEST mode is for checking the on-BD memory IC functioning. "GOOD" is displayed for normal ICs and "BAD" is displayed for abnormal ICs.

- When the test is completed, if the results are shown as above, it is satisfactory.
- If the test is not completed, the IC Board may have malfunctioned.
- After finishing the test, press the TEST BUTTON or START BUTTON to return to MENU mode.

8-4 INPUT TEST

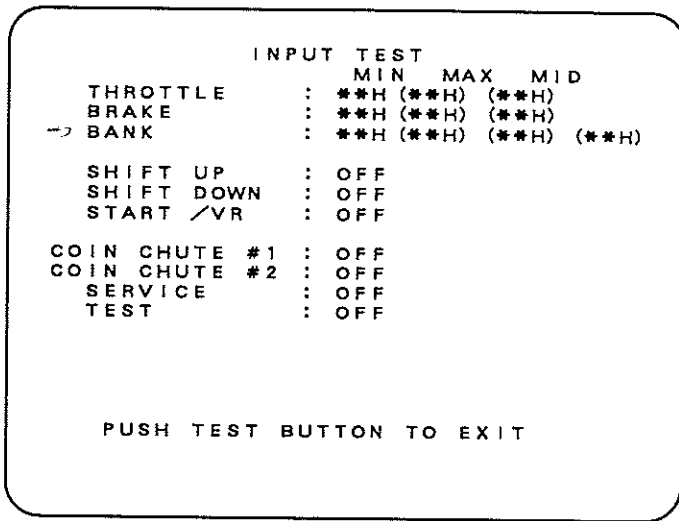

FIG. 8. 4a INPUT TEST

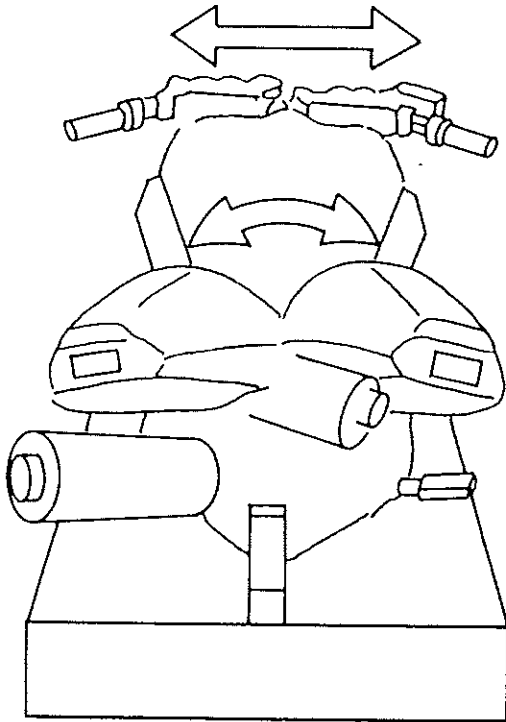

FIG. 8. 4b BANK

Selecting INPUT TEST causes the screen shown to appear and allows each switch status and game play related V. R. values to be checked. Also, in this mode, V. R. value setting can be performed.

On this screen, periodically check the status of each switch & V. R.

- By pressing each switch, if the display on the right-hand side of the name of each switch changes to ON from OFF, the SW and the wiring connections are satisfactory.
- To check CHUTE 1 & CHUTE 2 coin switches, open the COIN CHUTE DOOR and insert a coin(s) in the slot.
- To return to the MENU mode, press the TEST BUTTON.

V. R. SETTING PROCEDURE

- ① While pressing the SHIFT-UP button, press the START button to select the desired change item. Release the button to make the selection effective.
- ② With the SHIFT DOWN button pressed down, move the applicable device for shifting (throttle, brake and bank) fully within the applicable mobile range to set the value. When setting the bank V. R., where the button is released will be the center position.
- ③ Upon finishing the setting change, press the TEST button to have the menu mode return to the screen.

APPROPRIATE VALUE FOR EACH V. R.

To change V. R. securing position when replacing the V. R., etc. first secure the V. R. at a position displaying the following values. Then, perform V. R. setting in the above mentioned procedure.

THROTTLE : MIN. 2 0 H (without turning the THROTTLE GRIP)

BRAKE : 2 0 H (without pulling the BREAK LEVER)

BANK : MIN. 1 0 H center position ← 8 0 H → MAX. F 0 H
when inclined right when inclined left

8-5 SOUND TEST

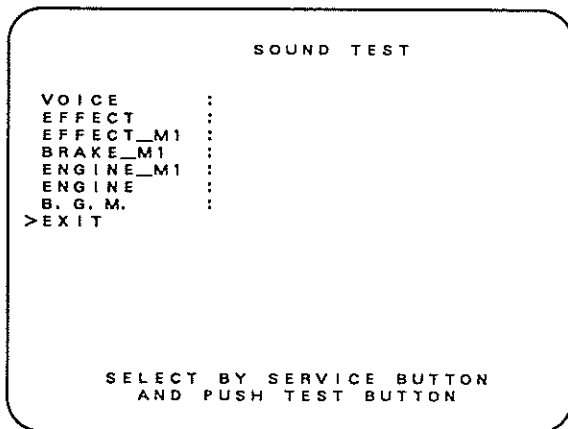

FIG. 8.5 SOUND TEST

- VOICE Announcement or comment during game.
- EFFECT Sound effects by the Game Board during game.
- EFFECT_M1 Sound effects by the Sound Board during game.
- BRAKE_M1 Brake sound by the Sound Board during game.
- ENGINE_M1 Engine sound by the Sound Board during game.
- ENGINE Engine sound by the Game Board during game.
- B. G. M. Background music during game.
- EXIT Causes the menu mode to return on to the screen.

Selecting SOUND TEST allows the desired sound (sound effects, announcement, BGM, etc.), to be chosen and heard. In this test, sound related IC Board and each speaker can be checked. Press the SERVICE button or SHIFT button to bring the arrow (>) to the desired sound test item. Pressing the TEST button or the START button allows the selected type of sound to be emitted. Each time the TEST button or START button is pressed, the next sound is emitted. The sound by the Sound BD is emitted via the bike body's left/right Speakers and the Superwoofer inside the muffler. Other sounds are emitted from the Front Cabinet's left/right Speakers.

8-6 C. R. T. TEST

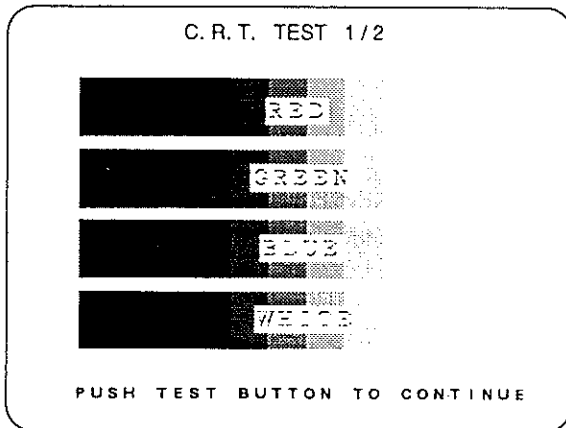

FIG. 8.6a C. R. T. TEST

Choose C.R.T. TEST to have the Monitor Adjustment check screen appear. By watching the screen, periodically check if adjustments are needed. For the Adjustment Method, refer to the Section of PROJECTOR. In the screen as per FIG. 8. 6a, check Monitor color adjustments. By watching this screen, make color adjustments. Each of the R (red), G (green) and B (Blue) and white is darkest at the left-hand end and becomes brighter towards the right-hand end.

Press the TEST button to have the following Crosshatch screen appear.

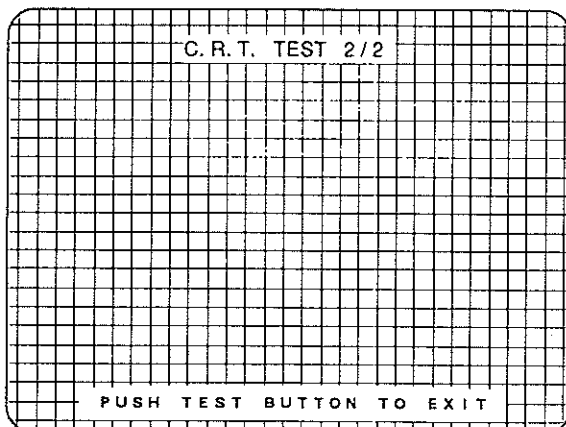

FIG. 8.6b C. R. T. TEST

In the screen as per FIG. 8.6b, check monitor size and position adjustments. Check size and position adjustments by watching this screen. Adjust the Monitor to make sure that the cross-hatch lines do not go beyond the screen size and crosshatch distortion does not occur.

Press the TEST button to have the menu return to the screen.

8-7 GAME ASSIGNMENTS

Select GAME ASSIGNMENTS to have the following screen appear. This allows settings of lap frequency, game difficulty level, etc. to be performed. Each item displays the contents described as follows:

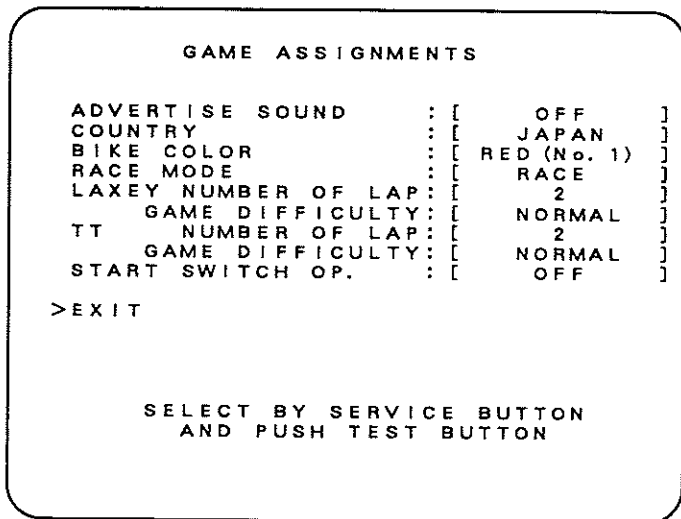

CAUTION!

At the same time the game starts, the bike body is unlocked. The bike will then bank in the direction of force exerted by the player. The bike suddenly inclines and this can cause injury. If unlocking the bike can very likely cause potentially hazardous situation, set START SWITCH OP. to "ON" for operation.

FIG. 8.7 GAME ASSIGNMENTS

SETTING CHANGE PROCEDURE



IMPORTANT!

Setting change is not effective until EXITing. Be sure to EXIT after setting change.

- ① Press the SERVICE button or SHIFT button to bring the arrow (>) to the desired change item.
- ② Press the TEST button or the START button to select the setting change item.
- ③ Move the arrow to EXIT and press the TEST button or the START button to return the menu mode to the screen.

- **ADVERTISE SOUND** Setting of sound to be emitted during Advertise mode.
OFF: No sound ON: Sound emitted.
- **COUNTRY** Allows for language setting.
- **BIKE COLOR** Selects bike color. At the same time, performs Seat order setting for communication play. For communication play, make sure that an identical number is not set to different seats.
- **RACE MODE** Select either RACE or T.T. (time trial).
- ****** NUMBER OF LAP** Lap frequency of each course.
- **GAME DIFFICULTY** This game allows by-course difficulty level to be set in 4 levels. Depending on the difficulty level set, the initial time varies.
- **START SWITCH OP.** Sets whether, at the time of game start, the START button is to be used or not.
OFF: Not Used. ON: To be used.

8-8 COIN ASSIGNMENT

The "COIN ASSIGNMENTS" mode permits you to set the start number of credits, as well as the basic numbers of coins and credits. This mode expresses "how many coins correspond to how many credits."

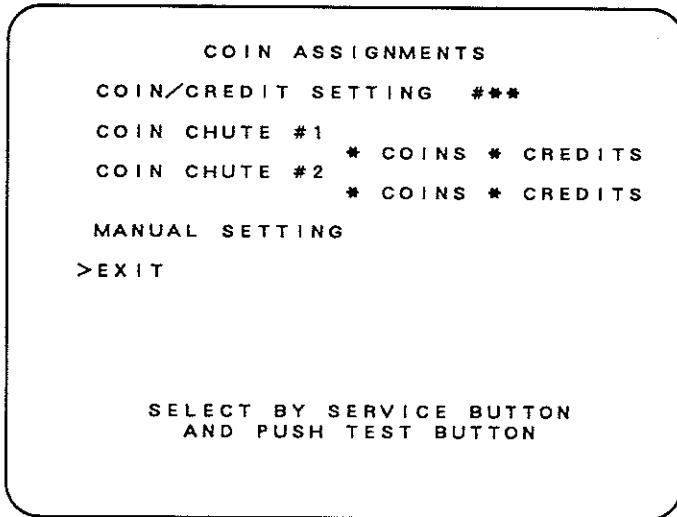

FIG. 8. 8a COIN ASSIGNMENTS

SETTING CHANGE PROCEDURE



IMPORTANT!

Setting change is not effective until EXITing. Be sure to EXIT after setting change.

- ① Press the SERVICE button or SHIFT button to bring the arrow (>) to the desired change item.
- ② Press the TEST button or the START button to select the setting change item.
- ③ Move the arrow to EXIT and press the TEST button or the START button to return the menu mode to the screen.

- COIN/CREDIT SETTING "How many coins correspond to how many credits."
In this machine, selection as per Table 8.8a is possible.
- MANUAL SETTING Allows for finer settings. (Table 8.8b)

TABLE 8.8 COIN/CREDIT SETTING (COIN CHUTE COMMON TYPE)

NAME OF SETTING	FUNCTIONING OF COIN CHUTE #1		FUNCTIONING OF COIN CHUTE #2	
SETTING #1	1 COIN	1 CREDIT	1 COIN	1 CREDIT
SETTING #2	1 COIN	2 CREDITS	1 COIN	1 CREDIT
SETTING #3	1 COIN	3 CREDITS	1 COIN	1 CREDIT
SETTING #4	1 COIN	4 CREDITS	1 COIN	1 CREDIT
SETTING #5	1 COIN	5 CREDITS	1 COIN	1 CREDIT
SETTING #6	1 COIN	2 CREDITS	1 COIN	2 CREDITS
SETTING #7	1 COIN	5 CREDITS	1 COIN	2 CREDITS
SETTING #8	1 COIN	3 CREDITS	1 COIN	3 CREDITS
SETTING #9	1 COIN	4 CREDITS	1 COIN	4 CREDITS
SETTING #10	1 COIN	5 CREDITS	1 COIN	5 CREDITS
SETTING #11	1 COIN	6 CREDITS	1 COIN	6 CREDITS
SETTING #12	2 COINS	1 CREDIT	2 COINS	1 CREDIT
SETTING #13	1 COIN	1 CREDIT	2 COINS	1 CREDIT
SETTING #14	1 COIN	2 CREDITS	2 COINS	1 CREDIT
SETTING #15	1 COIN	1 CREDIT	1 COIN	1 CREDIT
	2 COINS	3 CREDITS	2 COINS	3 CREDITS
SETTING #16	1 COIN	3 CREDITS	1 COIN	1 CREDIT
			2 COINS	3 CREDITS
SETTING #17	3 COINS	1 CREDIT	3 COINS	1 CREDIT
SETTING #18	4 COINS	1 CREDIT	4 COINS	1 CREDIT
SETTING #19	1 COIN	1 CREDIT	1 COIN	1 CREDIT
	2 COINS	2 CREDITS	2 COINS	2 CREDITS
	3 COINS	3 CREDITS	3 COINS	3 CREDITS
	4 COINS	5 CREDITS	4 COINS	5 CREDITS
SETTING #20	1 COIN	5 CREDITS	1 COIN	1 CREDIT
			2 COINS	2 CREDITS
			3 COINS	3 CREDITS
			4 COINS	5 CREDITS
SETTING #21	5 COINS	1 CREDIT	5 COINS	1 CREDIT
SETTING #22	1 COIN	2 CREDITS	3 COINS	1 CREDIT
			5 COINS	2 CREDITS
SETTING #23	2 COINS	1 CREDIT	2 COINS	1 CREDIT
	4 COINS	2 CREDITS	4 COINS	2 CREDITS
	5 COINS	3 CREDITS	5 COINS	3 CREDITS
SETTING #24	1 COIN	3 CREDITS	2 COINS	1 CREDIT
			4 COINS	2 CREDITS
			5 COINS	3 CREDITS
SETTING #25	1 COIN	1 CREDIT	1 COIN	1 CREDIT
	2 COINS	2 CREDITS	2 COINS	2 CREDITS
	3 COINS	3 CREDITS	3 COINS	3 CREDITS
	4 COINS	4 CREDITS	4 COINS	4 CREDITS
	5 COINS	6 CREDITS	5 COINS	6 CREDITS
SETTING #26	1 COIN	6 CREDITS	1 COIN	1 CREDIT
			2 COINS	2 CREDITS
			3 COINS	3 CREDITS
			4 COINS	4 CREDITS
			5 COINS	6 CREDITS
SETTING #27	FREE PLAY		FREE PLAY	

MANUAL SETTING

Selecting MANUAL SETTING in the Coin Assignment mode displays the following screen.

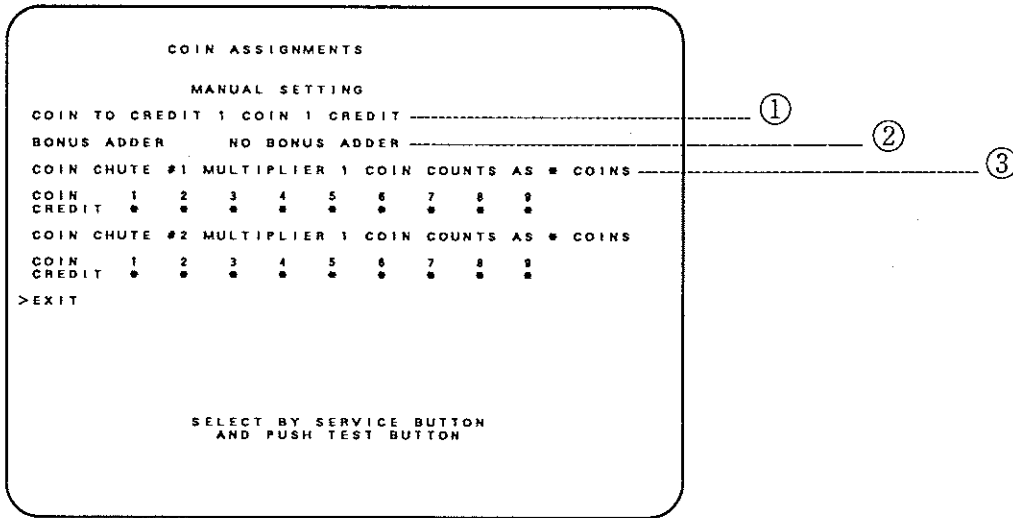

FIG. 8. 8b MANUAL SETTING

- ① Determines Coin /Credit setting.
- ② This sets how many coins should be inserted to obtain one Service Coin.
- ③ This sets how many tokens one coin represents.

Table 8. 8b MANUAL SETTING

COIN TO CREDIT	1 COIN	1 CREDIT
	2 COINS	1 CREDIT
	3 COINS	1 CREDIT
	4 COINS	1 CREDIT
	5 COINS	1 CREDIT
	6 COINS	1 CREDIT
	7 COINS	1 CREDIT
	8 COINS	1 CREDIT
	9 COINS	1 CREDIT

BONUS ADDER	NO BONUS ADDER
	2 COINS GIVE 1 EXTRA COIN
	3 COINS GIVE 1 EXTRA COIN
	4 COINS GIVE 1 EXTRA COIN
	5 COINS GIVE 1 EXTRA COIN
	6 COINS GIVE 1 EXTRA COIN
	7 COINS GIVE 1 EXTRA COIN
	8 COINS GIVE 1 EXTRA COIN
	9 COINS GIVE 1 EXTRA COIN

COIN CHUTE MULTIPLIER	1 COIN COUNTS AS 1 COIN
	1 COIN COUNTS AS 2 COINS
	1 COIN COUNTS AS 3 COINS
	1 COIN COUNTS AS 4 COINS
	1 COIN COUNTS AS 5 COINS
	1 COIN COUNTS AS 6 COINS
	1 COIN COUNTS AS 7 COINS
	1 COIN COUNTS AS 8 COINS
	1 COIN COUNTS AS 9 COINS

8-9 BOOKKEEPING

Selecting the BOOKKEEPING in the menu mode displays the bookkeeping data up to the present on the following 5 pages.

Each time the TEST button is pressed, the test item proceeds to the next item. Pressing the TEST button or the START button while the 5/5 screen is displayed returns the test menu on the screen.

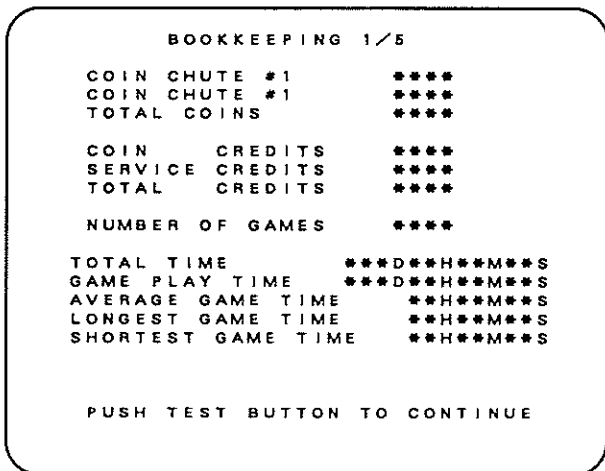

FIG. 8.9 a BOOKKEEPING (1/5)

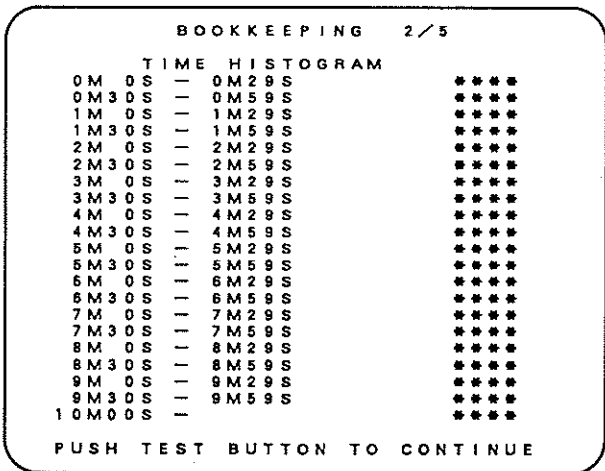

FIG. 8.9 b BOOKKEEPING (2/5)

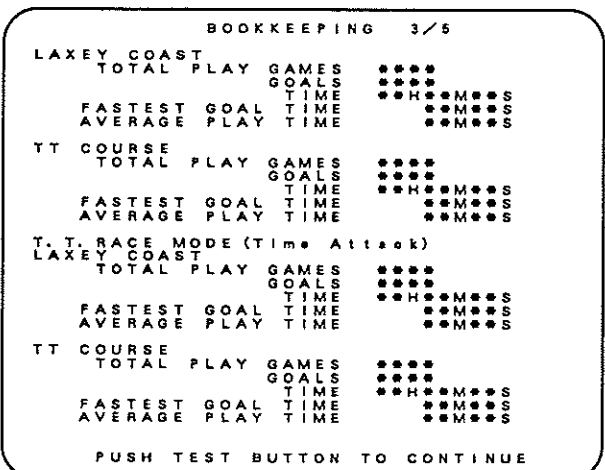

FIG. 8.9 c BOOKKEEPING (3/5)

- COIN CHUTE#*
Number of coins put in each chute.
- TOTAL COINS
Total number of coins inserted in each coin chute.
- COIN CREDITS
Number of credits registered by inserting coins
- SERVICE CREDITS
Credits registered by the SERVICE button
- TOTAL CREDITS
Total number of credits
(COIN CREDITS + SERVICE CREDITS)
- TOTAL TIME
The total energized time.
- TIME HISTOGRAM
By-playtime play frequency.

The 2/5 screen displays by-play-time play frequency. For difficulty setting, etc., refer to this screen.

The 3/5 screen displays by-course play frequency and play time.

BOOKKEEPING 4/5											
LAXEY COAST RANKING [10]											
	TOTAL TIME					LAP TIME					
1	**'	**'	**'	**'	**'	AT	**'	**'	**'	**'	AT
2	**'	**'	**'	**'	**'	AT	**'	**'	**'	**'	AT
3	**'	**'	**'	**'	**'	AT	**'	**'	**'	**'	AT
4	**'	**'	**'	**'	**'	AT	**'	**'	**'	**'	AT
5	**'	**'	**'	**'	**'	AT	**'	**'	**'	**'	AT
6	**'	**'	**'	**'	**'	AT	**'	**'	**'	**'	AT
7	**'	**'	**'	**'	**'	AT	**'	**'	**'	**'	AT
8	**'	**'	**'	**'	**'	AT	**'	**'	**'	**'	AT
9	**'	**'	**'	**'	**'	AT	**'	**'	**'	**'	AT
10	**'	**'	**'	**'	**'	AT	**'	**'	**'	**'	AT
TT COURSE RANKING [10]											
	TOTAL TIME					LAP TIME					
1	**'	**'	**'	**'	**'	MT	**'	**'	**'	**'	MT
2	**'	**'	**'	**'	**'	MT	**'	**'	**'	**'	MT
3	**'	**'	**'	**'	**'	MT	**'	**'	**'	**'	MT
4	**'	**'	**'	**'	**'	MT	**'	**'	**'	**'	MT
5	**'	**'	**'	**'	**'	MT	**'	**'	**'	**'	MT
6	**'	**'	**'	**'	**'	MT	**'	**'	**'	**'	MT
7	**'	**'	**'	**'	**'	MT	**'	**'	**'	**'	MT
8	**'	**'	**'	**'	**'	MT	**'	**'	**'	**'	MT
9	**'	**'	**'	**'	**'	MT	**'	**'	**'	**'	MT
10	**'	**'	**'	**'	**'	MT	**'	**'	**'	**'	MT

FIG. 8.9 d BOOKKEEPING (4/5)

The 4/5 screen displays by-course ranking up to the 10th position in the case of RACE mode.

BOOKKEEPING 5/5											
T. T. Race Mode (Time Attack)											
LAXEY COAST RANKING [10]											
	TOTAL TIME					LAP TIME					
1	**'	**'	**'	**'	**'	AT	**'	**'	**'	**'	AT
2	**'	**'	**'	**'	**'	AT	**'	**'	**'	**'	AT
3	**'	**'	**'	**'	**'	AT	**'	**'	**'	**'	AT
4	**'	**'	**'	**'	**'	AT	**'	**'	**'	**'	AT
5	**'	**'	**'	**'	**'	AT	**'	**'	**'	**'	AT
6	**'	**'	**'	**'	**'	AT	**'	**'	**'	**'	AT
7	**'	**'	**'	**'	**'	AT	**'	**'	**'	**'	AT
8	**'	**'	**'	**'	**'	AT	**'	**'	**'	**'	AT
9	**'	**'	**'	**'	**'	AT	**'	**'	**'	**'	AT
10	**'	**'	**'	**'	**'	AT	**'	**'	**'	**'	AT
TT COURSE RANKING [10]											
	TOTAL TIME					LAP TIME					
1	**'	**'	**'	**'	**'	MT	**'	**'	**'	**'	MT
2	**'	**'	**'	**'	**'	MT	**'	**'	**'	**'	MT
3	**'	**'	**'	**'	**'	MT	**'	**'	**'	**'	MT
4	**'	**'	**'	**'	**'	MT	**'	**'	**'	**'	MT
5	**'	**'	**'	**'	**'	MT	**'	**'	**'	**'	MT
6	**'	**'	**'	**'	**'	MT	**'	**'	**'	**'	MT
7	**'	**'	**'	**'	**'	MT	**'	**'	**'	**'	MT
8	**'	**'	**'	**'	**'	MT	**'	**'	**'	**'	MT
9	**'	**'	**'	**'	**'	MT	**'	**'	**'	**'	MT
10	**'	**'	**'	**'	**'	MT	**'	**'	**'	**'	MT

FIG. 8.9 e BOOKKEEPING (5/5)

The 5/5 screen displays by-course ranking up to the 10th position in the case of T.T. (Time Trial) mode.

8-10 BACKUP DATA CLEAR

BACKUP DATA CLEAR	
YES (CLEAR)	
>	NO (CANCEL)
SELECT BY SERVICE BUTTON AND PUSH TEST BUTTON	

FIG. 8.10 BACKUP DATA CLEAR

Clears the contents of BOOKKEEPING. When clearing, use the SERVICE BUTTON to bring the arrow (>) to "YES (CLEAR)" and press the TEST BUTTON. When the data has been cleared, "COMPLETED" will be displayed.

Bring the arrow to "NO (CANCEL)" and press the TEST BUTTON to return to the Menu mode without clearing the data.

Also, note that the game setting contents are not affected by BACKUP DATA CLEAR operation.

8-11 OUTPUT TEST

In the OUTPUT TEST, connections between IC Boards, the status of each motor and lamp can be checked. In this mode, periodically check these items.

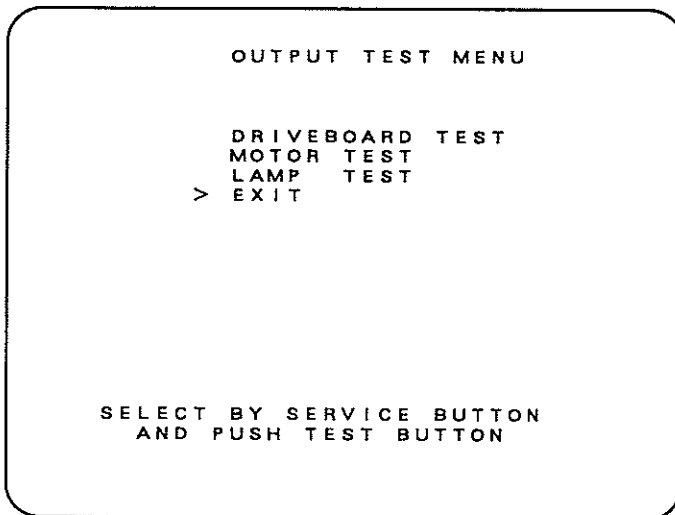

FIG. 8.11 a TEST MENU IN THE OUTPUT TEST MODE

In the menu mode, selecting OUTPUT TEST causes the menu (FIG. 8.11 a) in the OUTPUT TEST mode to appear on the screen. Select the desired test item in the OUTPUT TEST mode. Upon finishing each test, first return the OUTPUT TEST menu to the screen, and then choose EXIT to return to the menu screen and exit from the test mode.

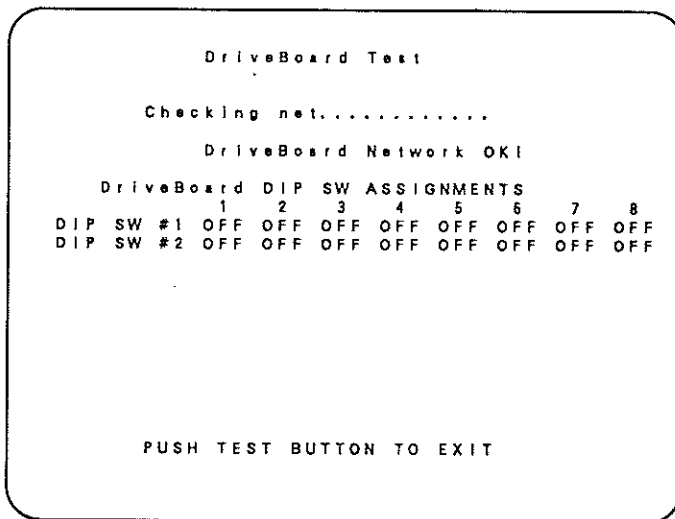

FIG. 8.11 b DRIVE BOARD TEST

In the OUTPUT TEST menu mode, selecting DRIVE BOARD TEST allows for checking connections between and functioning of the Drive BD and Game BD as well as each V. R. and motors. After checking, if "Drive Board Network is OK!" is displayed, the testing is satisfactory. For irregularity, ERROR display will be indicated. Check connections between the Drive Board, the Game Board, each V. R. and motor. Also check each V. R. and motor.

"Drive Board DIP SW ASSIGNMENTS" displays DIP SW setting on the Drive Board at the time of Drive Board test. When DIP SW setting is changed, be sure to turn the power off and then turn it back on again to make the setting change effective.

For the operation of this machine, set all of the dip switches to OFF. Make sure that all are set to OFF in this screen mode. Press either TEST button or START button to return the OUTPUT TEST menu mode to the screen.



IMPORTANT!

In this machine, DIP SW setting is for in-factory checking. For actual operation, set all the DIP SWes to OFF. Setting to ON may not be appropriate for practical operation.

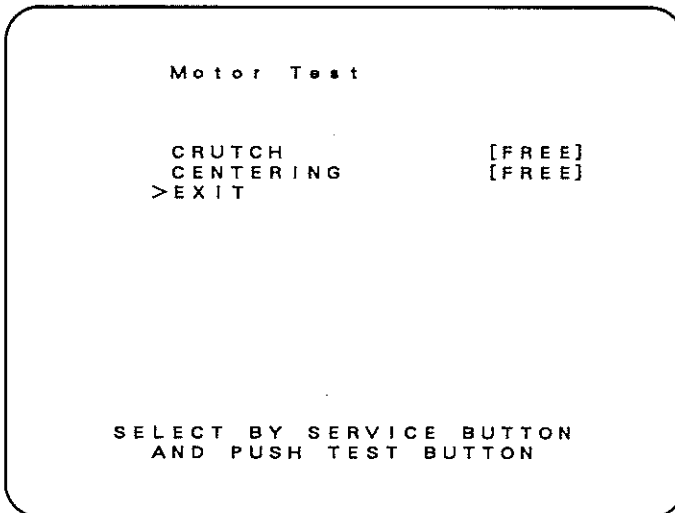
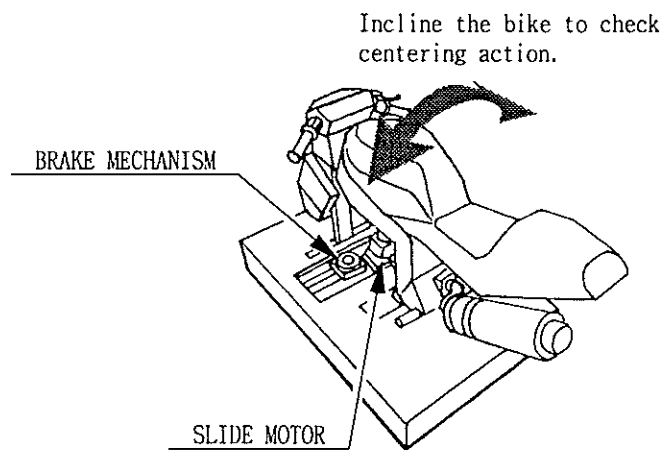

FIG. 8.11 c MOTOR TEST



IMPORTANT!

Only during motor test, use the START button for moving the arrow and SHIFT-UP/DOWN for CRUTCH and CENTERING setting changes.

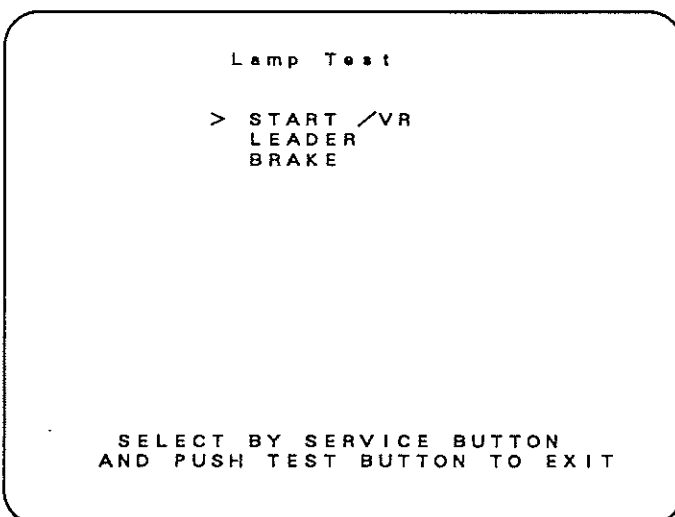

FIG. 8.11 d LAMP TEST

In the OUTPUT TEST menu mode, selecting MOTOR TEST displays the screen on which motor and brake functioning check is performed.

● CRUTCH

Performs brake mechanism functioning check. Setting change causes the brake to function as follows:

- FREE: Unlocked
- BRAKE: Locked

● CENTERING

Performs Slide (Centering) Motor functioning check. Setting change causes the motor to function as follows:

- FREE: Motor centering is cancelled.
- MOTOR: Executes centering.

● EXIT

Returns the OUTPUT TEST menu mode to the screen.

Changing to "BRAKE" from "CRUTCH" secures the bike body. Therefore, even if "CENTERING" setting is changed, the bike will not move. With the bike inclined, changing to "BRAKE" from "CRUTCH" secures the bike in the inclined status. For motor checking, change "CENTERING" setting with "CRUTCH" set to "FREE." With "CENTERING" set to "FREE," the bike can easily be inclined as there will be no load in the direction of centering. The inclined bike performs centering gradually via SUB-CENTERING MECHANISM. Setting to "MOTOR" allows for centering by motor.

Selecting LAMP TEST in the OUTPUT TEST menu mode displays the screen on which each lamp's functioning check is performed.

If the lamp selected (where the arrow is) flashes, the lamp and its wiring connections are satisfactory.

Press either the TEST button or the START button to return the OUTPUT TEST menu mode to the screen.

9. HANDLE MECHANISM

In the Test Mode, if Throttle and Brake V.R. value variations can not be set within the allowable range, V. R. installation position adjustment or V. R. replacement are needed. Also, make sure to apply grease to the Throttle/Brake mechanism once every 6 months. To perform the above work, remove the Handle Cover and Brake Cover. (When replacing the Throttle V. R., however, remove only the Handle Cover.) When replacing the START button, first remove the wiring connected to the START button and then remove the START button from the Handle Cover.

REMOVING THE HANDLE COVER AND BRAKE COVER



- When working, be sure to turn power off. Working without turning power off can cause electric shock or short circuit accident.
- Be careful so as not to cause damage to wirings. Damaged wiring can cause an electric shock or short circuit accident.

For Throttle/Brake V.R. adjustment, remove the Handle Cover and Brake Cover by using the following procedure. There is a connector's wiring connection inside the Handle Cover. Be very careful so as not to damage the wiring.

- ① Remove the 5 screws which secure the Handle Cover.
- ② Remove the 4 screws which secure the Brake Cover.
- ③ The Handle Cover is removable from the Handle Unit as per ① above. Disconnect the connector to remove the Handle Cover from the Handle Mecha. Then, the Brake Cover is removable.

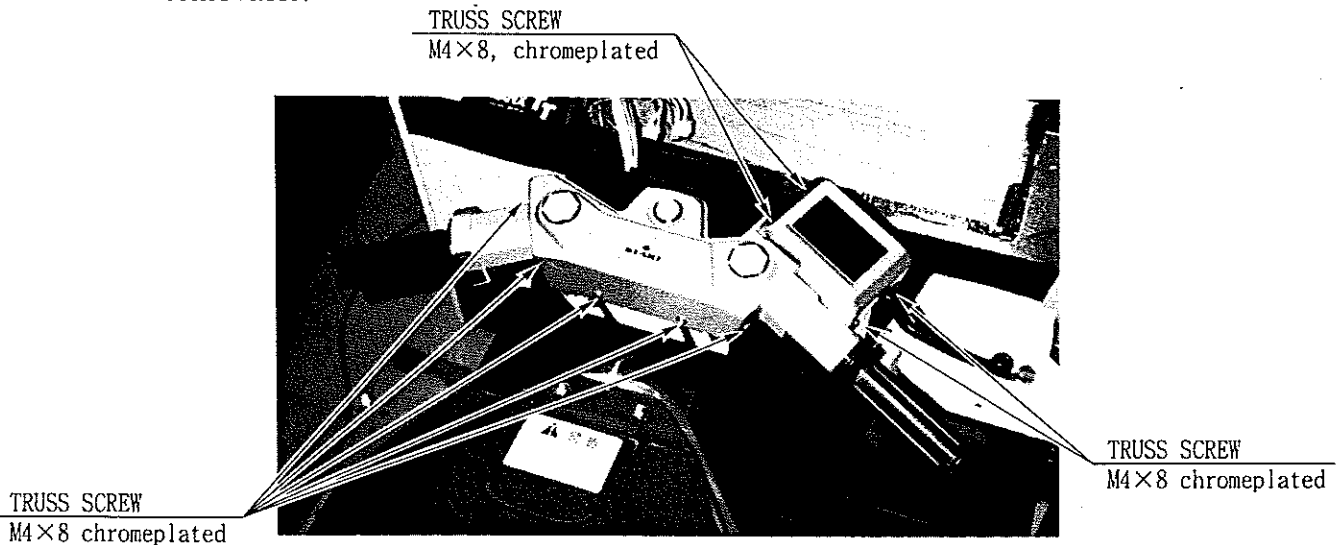

FIG. 9 a

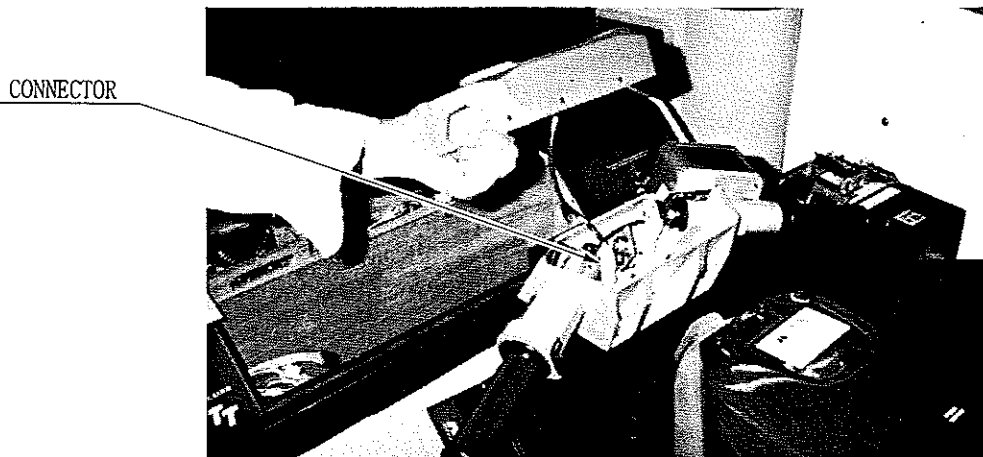

FIG. 9 b

9-1 ACCELERATOR/BRAKE V. R. ADJUSTMENT



Do not touch places other than those specified. Touching places not specified can cause an electric shock or short circuit accident.

This machine has V. R. setting functions. Game is playable satisfactorily if the V. R. Shaft can rotate without any problem within the mobile range of the Grip and Brake Lever. Display the INPUT TEST mode, and while maintaining the status without applying the Throttle and brake respectively to the Grip and Brake Lever, follow the procedure below to make V. R. adjustments.

ADJUSTING THE THROTTLE V. R.

- ① Remove the Handle Cover.
- ② Loosen Screw A and move the Gear to ensure that the variation value in the V. R. adjustment mode is within 20H plus or minus 10.
- ③ If the value is within the specified range, retighten Screw A.
- ④ Perform V. R. setting. (Refer to 8-4)

ADJUSTING THE BRAKE V. R.

- ① Remove the Handle Cover and then remove the Brake Cover.
- ② Loosen Screw B and move the Gear to ensure that the variation value in the V. R. adjustment mode is within 20H plus or minus 10.
- ③ If the value is within the specified range, retighten Screw B.
- ④ Perform V. R. setting. (Refer to 8-4.)

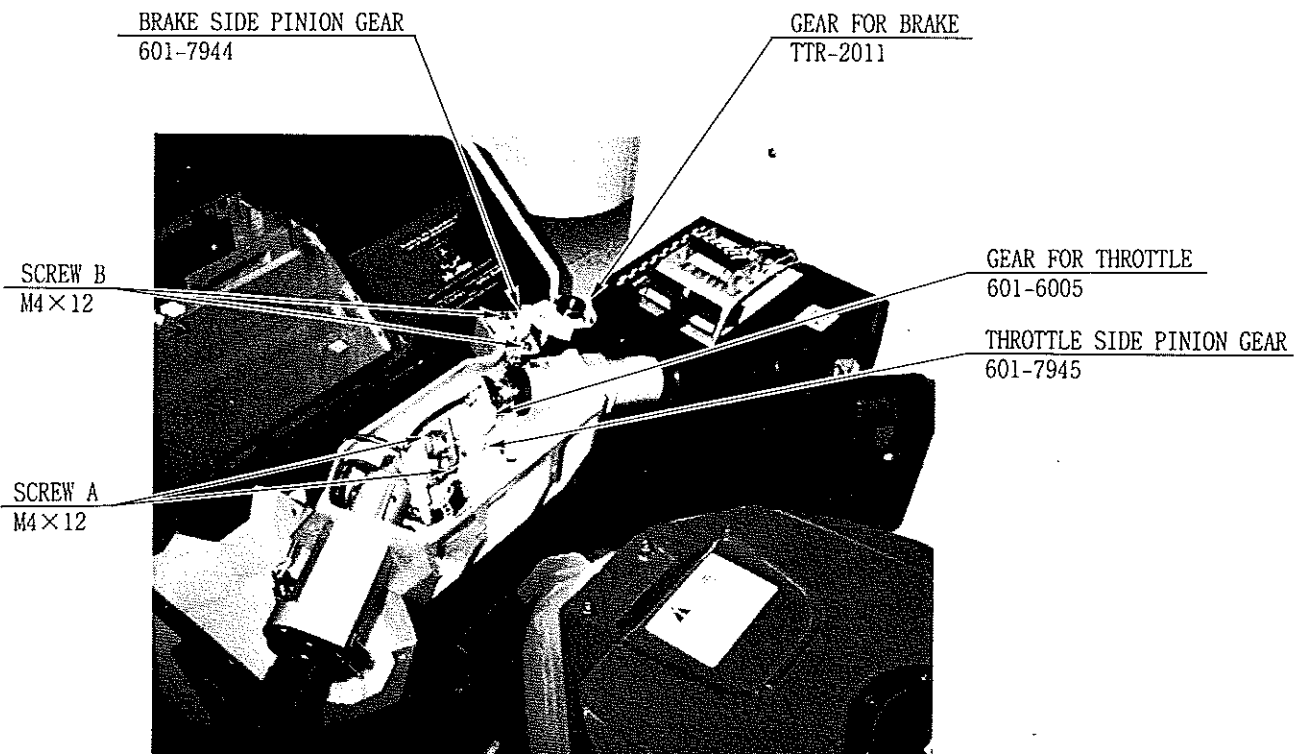

FIG. 9.1

9-2 THROTTLE/BRAKE V. R. REPLACEMENT



When replacing the VOLUME, be sure to turn power off. Performing replacement work without turning power off can cause electric shock or short circuit accident.

REPLACEMENT PROCEDURE

For V. R. replacement, turn the V. R. shaft to the periphery of V. R. shaft angle in which the V. R. value is the minimum, engage the Gears and secure the V. R. Bracket. At this time, make sure that the throttle and brake are not applied respectively to the Grip and Brake Lever. Game is playable satisfactorily if the V. R. shaft rotates without any problem within the mobile range of the Grip and the Lever.

- ① Take out the 2 screws which secure the V. R. Bracket to remove the Bracket from the Handle Unit.
- ② To remove the PINION GEAR, loosen the 2 Set Screws of the Pinion Gear attached to the Shaft of the V. R. to be replaced.
- ③ Take out Nut A from the V. R. Shaft to remove the V. R. from the Bracket.
- ④ After replacement, assemble in the procedure opposite to the above.
- ⑤ In the Test Mode, perform V. R. setting. (Refer to 8-4.)

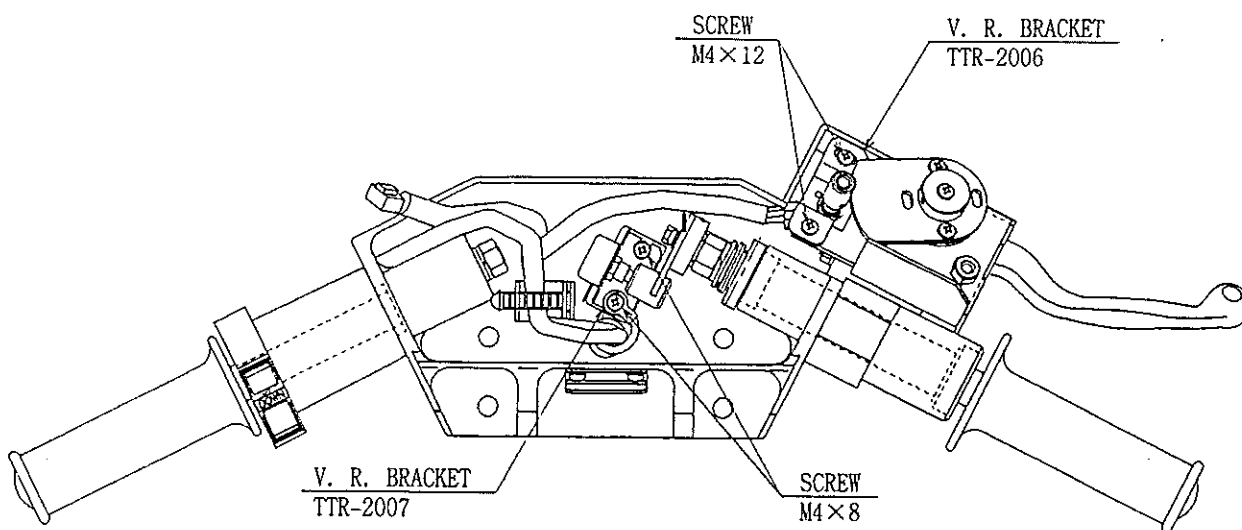
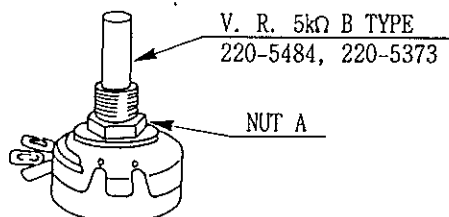

FIG. 9.2



9-3 GREASING



Be sure to apply specified grease. Using grease other than that specified can damage parts.

Apply spray greasing once every 6 months to the 2 places shown in FIG. 9.3 where the spring and gear are engaged. For spray grease, use NOK KLUBER L60 or GREASE MATE (PART No. 090-0060).

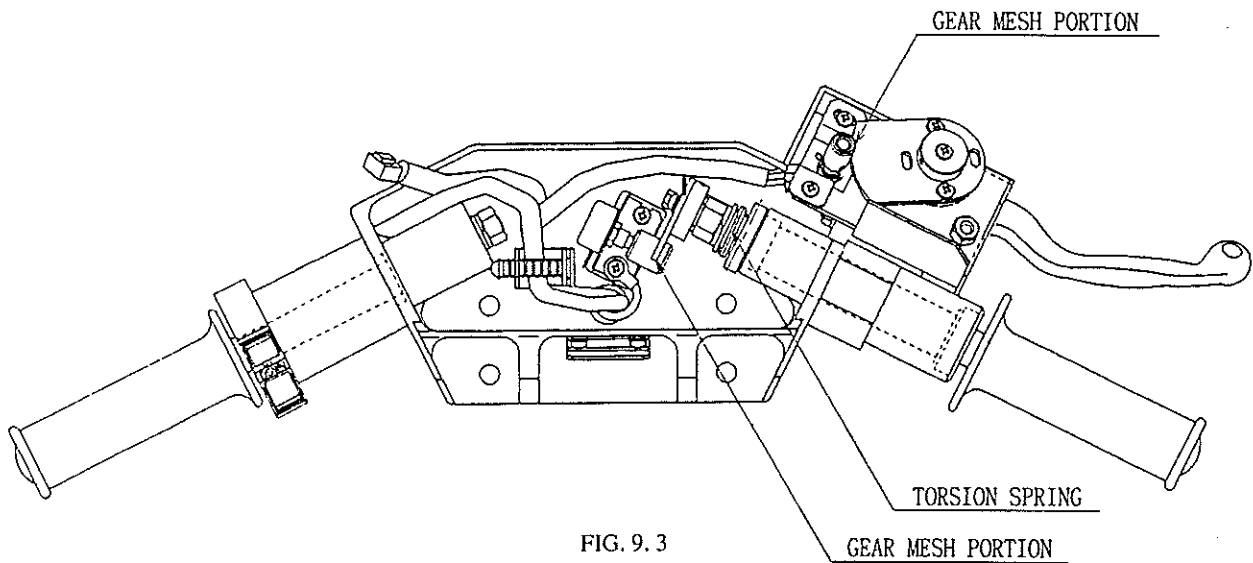

FIG. 9.3

9-4 SPRING REPLACEMENT



When replacing the SPRING, be sure to turn power off. Working without turning power off can cause electric shock or short circuit accident.

As shown in FIG. 9.4, remove parts to replace the Torsion Spring.

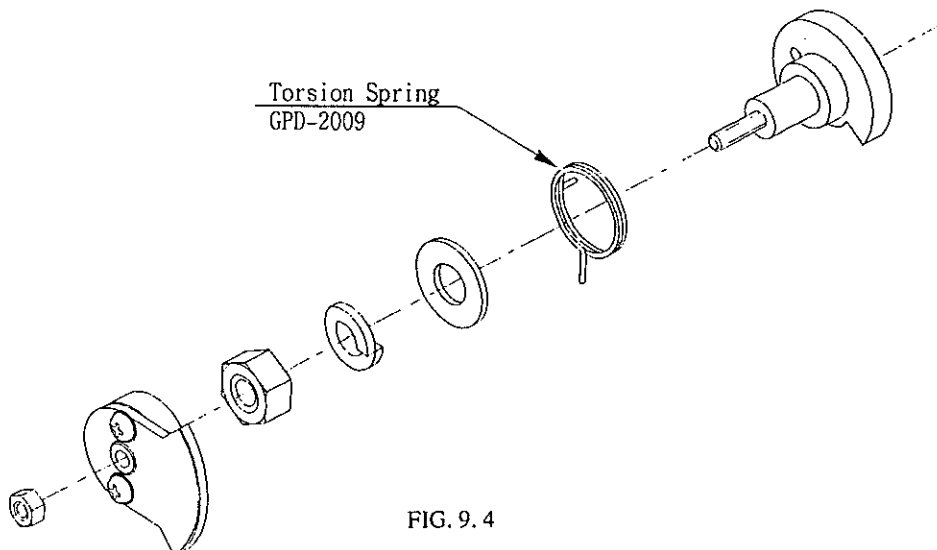
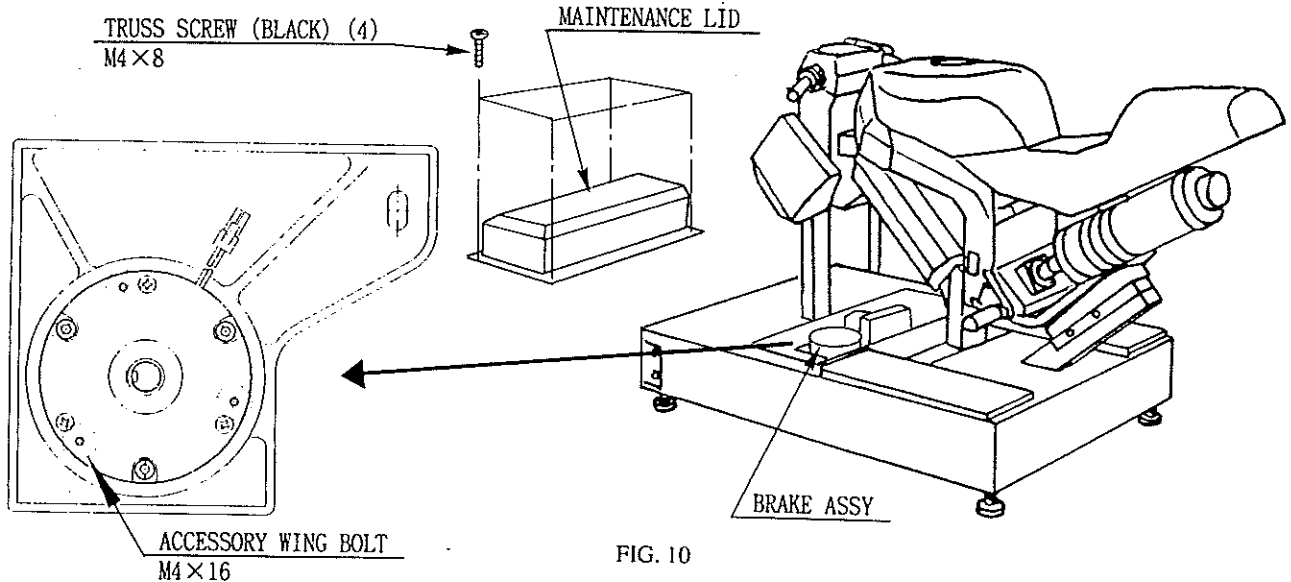

FIG. 9.4

10. REAR BASE

When inspecting and adjusting each part, in the status of POWER OFF, the bike body is locked and can not be inclined left and right. To bank it left and right, unlock the brake. First open the Maintenance Lid. Next, screw the 3 accessory Wing Bolts (M4×16) into the Brake Assy holes shown. The Brake will be unlocked and the bike body can be banked. Upon finishing inspection and adjustment, be sure to remove the Wing Bolts.



10-1 VOLUME (V. R.) REPLACEMENT



When replacing the VOLUME, be sure to turn power off. Performing replacement work without turning power off can cause electric shock or short circuit accident.

Replace the bike's bank angle V. R. in the following procedure.

- ① Take out the 4 hexagon socket head bolts to remove the Fuel Cap.
- ② Take out a total of 3 bolts which secure the Tank to remove the Tank.

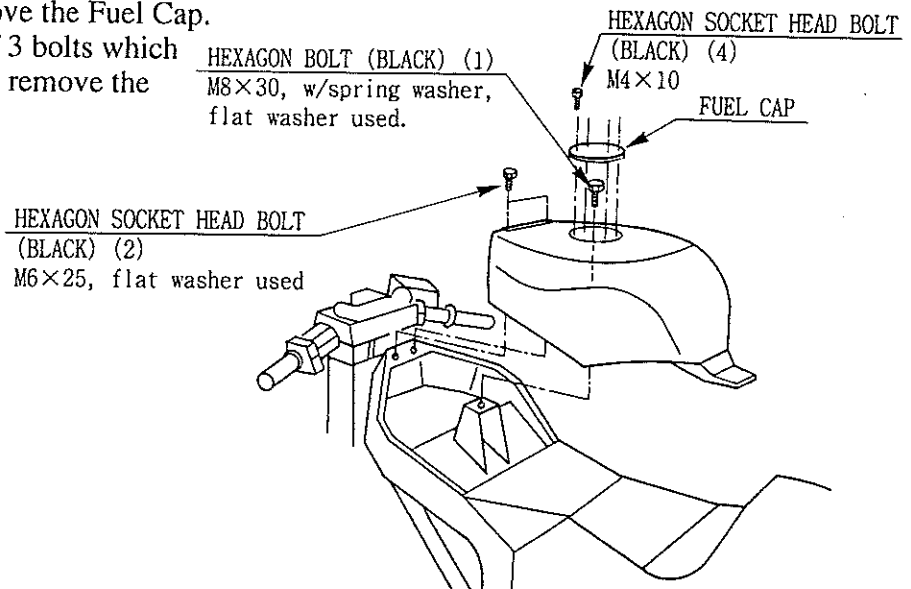

FIG. 10.1 a

- ③ Take out the 4 Truss Screws and 2 Cap Nuts to remove MECHA COVER L.
- ④ Take out the 2 screws and the Connector to remove the V. R. shown together with the Bracket.
- ⑤ After V. R. replacement, make adjustment of gear mesh in the manner so that when the bike body is banked, the V. R. shaft does not rotate beyond the shaft's predetermined rotation range.
- ⑥ After the adjustment is finished, install Mecha Cover L, Tank, and Fuel Cap.
- ⑦ After assembly, perform V. R. setting in the Test Mode.

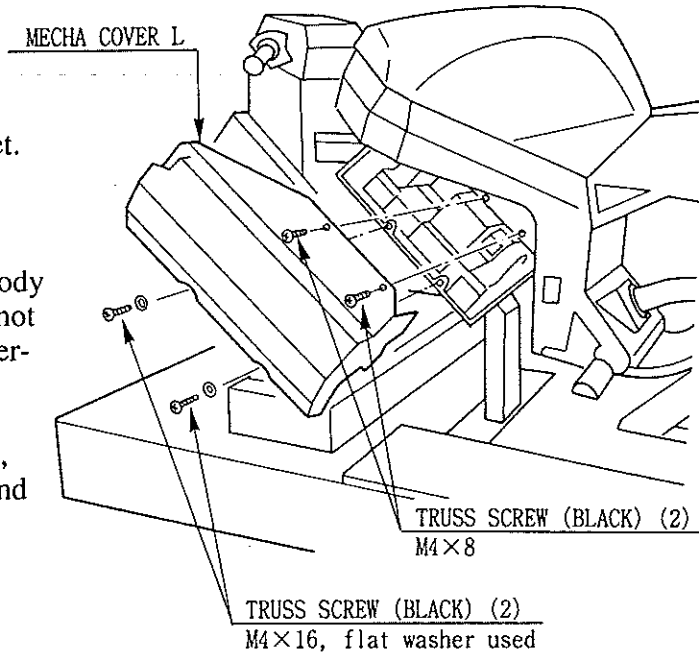

FIG. 10. 1 b

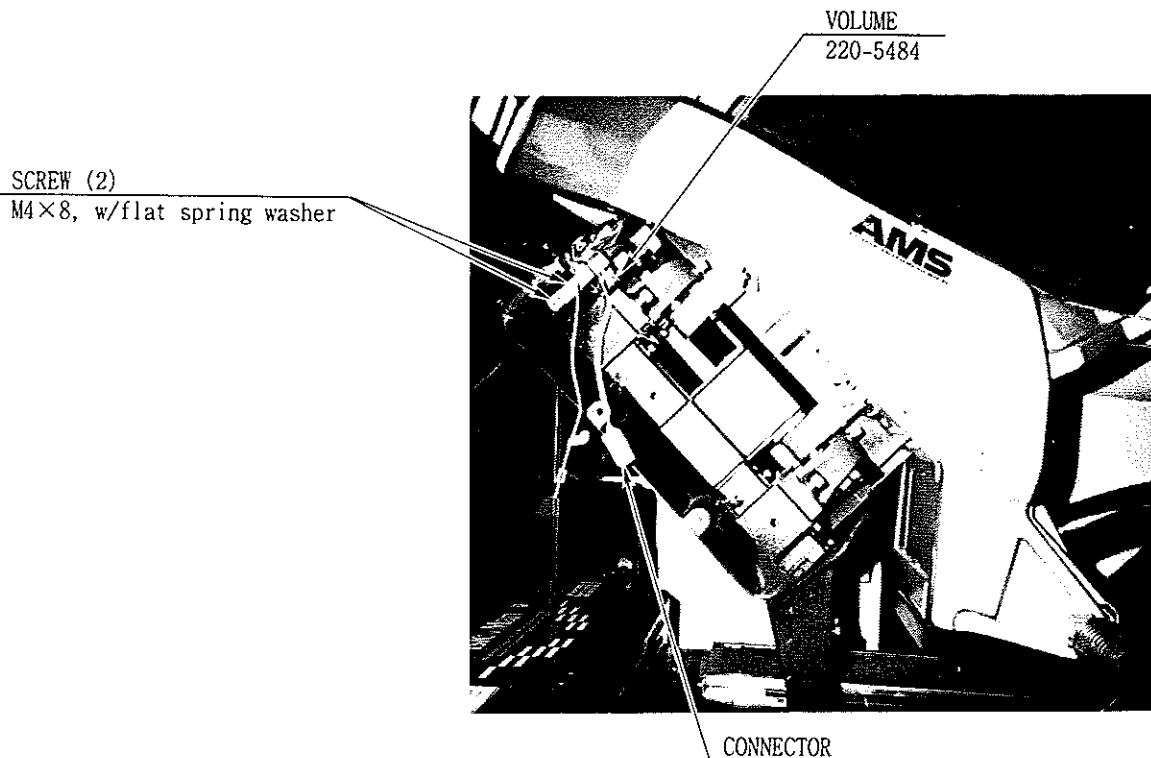

FIG. 10. 1 c

10-2 INSPECTION AND REPLACEMENT OF PINION GEAR



- Do not touch places other than those specified. Touching places not specified can cause an electric shock or short circuit accident.
- When replacing the PINION GEAR, be sure to turn power off. Performing replacement work without turning power off can cause electric shock or short circuit accident.

- ① Remove the 4 Truss Screws to open the Maintenance Lid.
- ② As shown in the figure, take out the 4 Hexagon Bolts and disconnect the 3 Connectors to remove the Slide Motor together with the Bracket.
- ③ Check the Pinion Gear and if gear teeth are worn out or omitted, replace the Pinion Gear.
- ④ After replacing the Gear, install the motor to the frame with the keyway matching the direction shown. At this time, secure the Slide Motor after pressing the Bracket to the Rack side in the manner so that the gear & rack backlash becomes zero.
- ⑤ After assembly, apply grease to the Gear and Rack.
- ⑥ Turn power on and check if gear & rack mesh is correct. If the mesh is incorrect, the motor makes big noise when it rotates.
- ⑦ After checking and adjustment, close the Maintenance Lid.

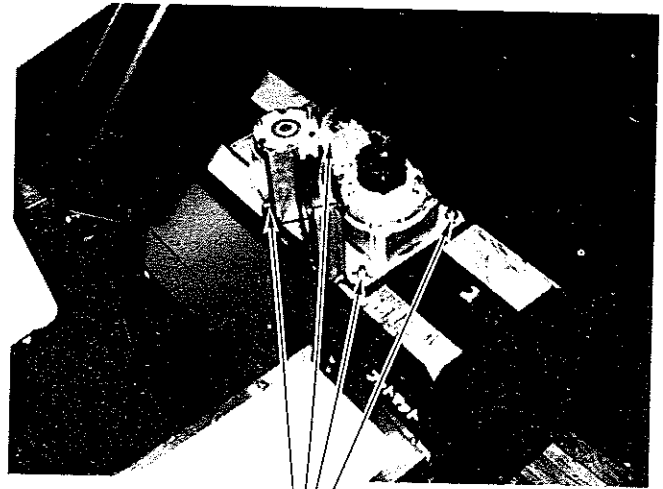

Hexagon Bolt (4)
M8×20, w/spring washer,
flat washer used

FIG. 10. 2 a

Motor Shaft Keyway to be
in the direction of the arrow.

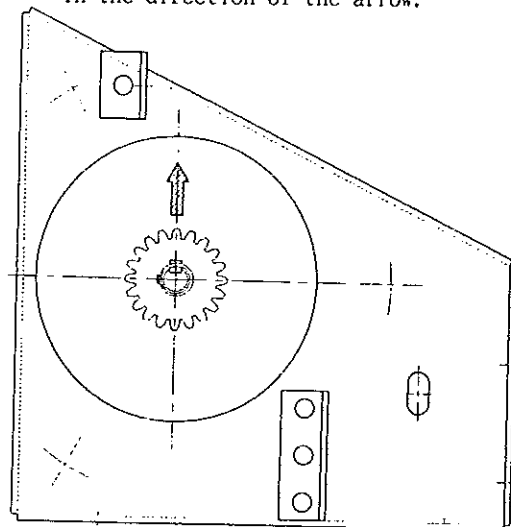

FIG. 10. 2 b

10-3 GREASING



CAUTION!

Be sure to apply specified grease. Using grease other than that specified can damage parts.

In this machine, greasing need to be applied to the mobile parts once every 6 months. For spray grease, use NOK KLUBER L60 or GREASE MATE (Part No. 090-0060).

- ① Take out the 4 Truss Screws to open the Maintenance Lid.
- ② Apply spray grease to the 2 rail portions & rack portion inside the Base.
- ③ Turn over the Safety Rubber and apply greasing to the Guide portion.

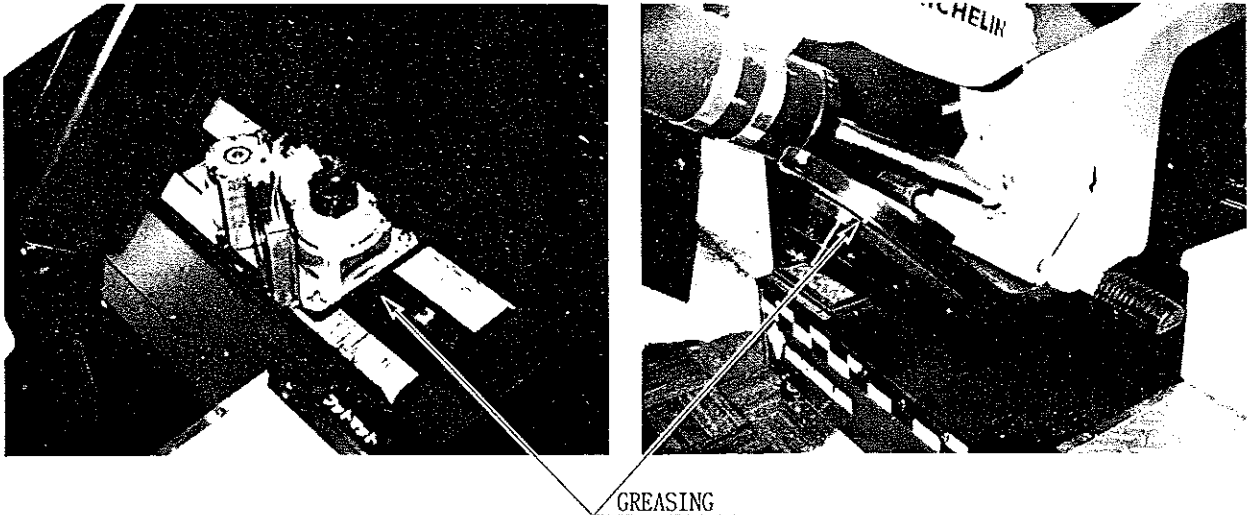

FIG. 10.3

10-4 REPLACEMENT OF SAFETY RUBBER



CAUTION!

The SAFETY RUBBER is an important, hazard preventative part. Before commencing daily operation, be sure to check for damage and omission. Operating with the Safety Rubber damaged and omitted can cause injury such as the player's finger(s) being caught (in the damaged or omitted portion).

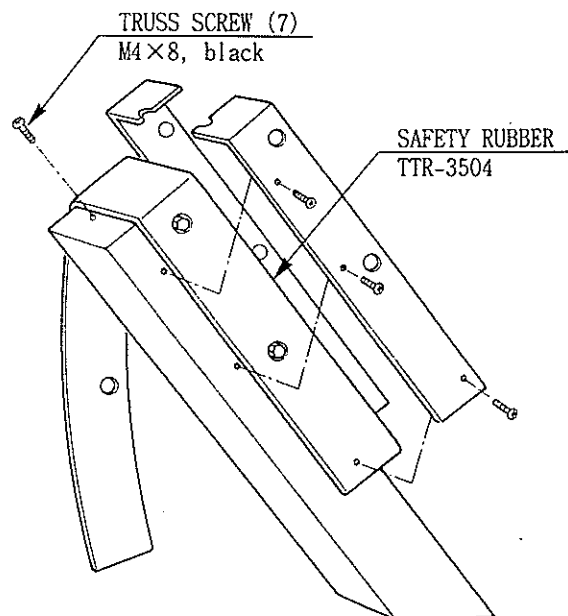

FIG. 10.4

11. COIN SELECTOR

HANDLING THE COIN JAM

If the coin is not rejected even when the REJECT button is pressed, open the coin chute door and open the selector gate. After removing the jammed coin, put a normal coin in and check to see that the selector correctly functions.

CLEANING THE COIN SELECTOR

The coin selector should be cleaned once every 3 months. When cleaning, follow the procedure below:

- ① Turn the power for the machine OFF. Open the coin chute door.
- ② Open the gate and dust off by using a soft brush (made of wool, etc.).
- ③ Remove and clean smears by using a soft cloth dipped in water or diluted chemical detergent and then wrung.
- ④ Remove the CRADLE.
When removing the retaining ring (E ring), be very careful so as not to bend the shaft.
- ⑤ Remove stain from the shaft and pillow portions by wiping off with a soft cloth, etc.
- ⑥ After wiping off as per ⑤ above, further apply a dry cloth, etc. to cause the coin selector to dry completely.



- Never apply machine oil, etc. to the Coin Selector.
- After cleaning the Coin Selector, insert a regular coin in the normal working status and ensure that the Selector correctly functions.

COIN INSERTION TEST

Once every month, when performing the Coin SW Test, simultaneously check the following:

- Does the Coin Meter count satisfactorily?
- Does the coin drop into the Cashbox correctly?
- Is the coin rejected when inserted while keeping the Reject Button pressed down?

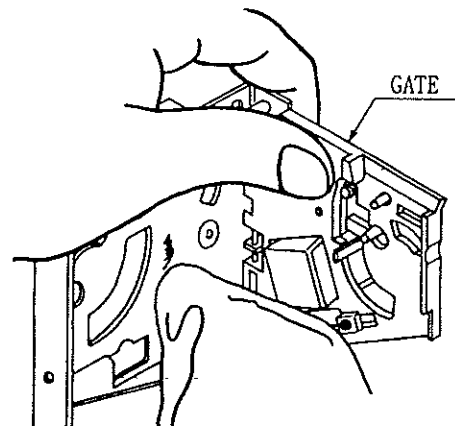

FIG. 11 a

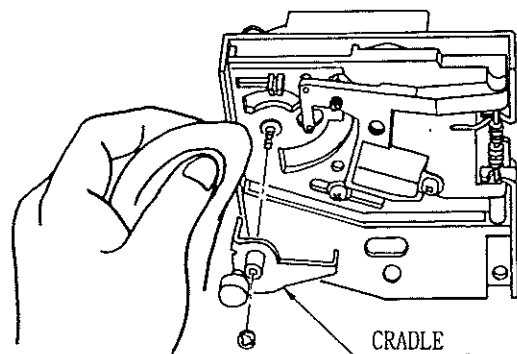
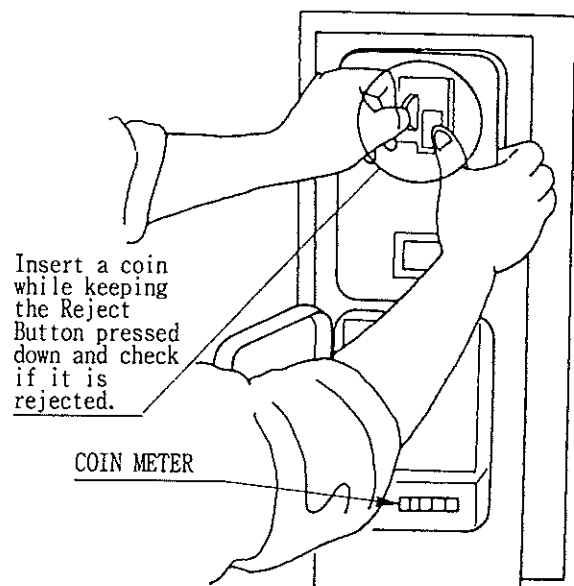

FIG. 11 b



Insert a coin while keeping the Reject Button pressed down and check if it is rejected.

FIG. 11 c

12. PROJECTOR



CAUTION!

- Since the Projector screen is susceptible to damage, pay careful attention to its handling. When cleaning, refrain from using water or volatile chemicals.
- Since the Projector has been adjusted at the time of shipment, avoid making further adjustments without good reason.

Fine adjustments are stored in the Projector. Pressing the Fine Adjustment SW (Convergence Adjustment) results in entering the Fine Adjustment mode, and this may cause the stored fine adjustment to be changed. During work other than for adjustment, should you touch the Fine Adjustment SW by mistake, immediately turn the power off by using the main SW and then turn it back on again. If any distortion or color deviation is found in the test mode and adjustments are needed, use the specified Adjustment knob, or perform the adjustment by remote control. Note that there are two PROJECTOR makes (HITACHI & MITSUBISHI) and the adjustment method is different between the two. When checking the Adjustment Control knob, remove the PTV's Service Door. For the HITACHI Projector, open the cover in front of the control panel. For the MITSUBISHI Projector, remove the cover.



IMPORTANT!

The Projector is subject to color deviation due to Convergence deviation caused by the geomagnetism at the installation location and peripheral magnetic field. After the installation of machine, and before commencing operation, check for Convergence deviation and if deviated, make adjustments.

12-1 CLEANING THE SCREEN

When the screen surface becomes dirty with dust, etc., clean it by using a soft cloth such as gauze. When water, and volatile chemicals such as benzine, thinner, etc., spill on the screen surface, it may be subject to damage, therefore, do not use them. Also, since the surfaces are susceptible to damage, refrain from rubbing them with a hard material or using a duster.

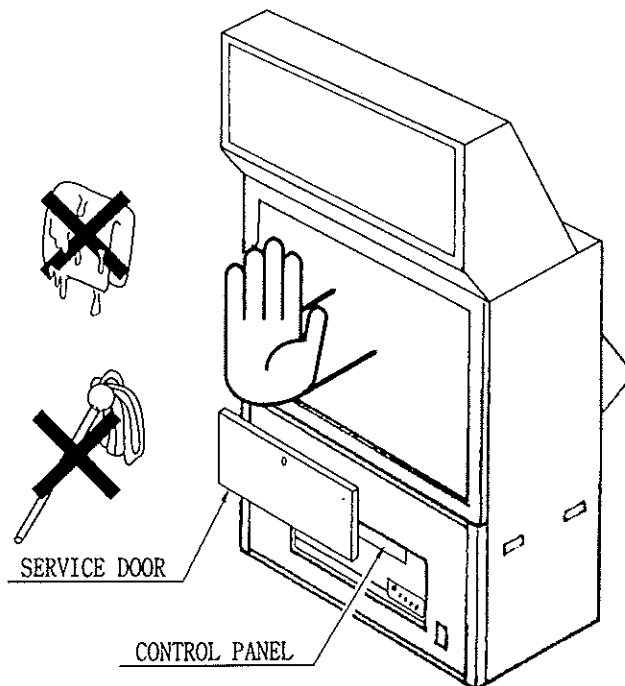

12-2 ADJUSTING HITACHI PROJECTORS



CAUTION!

Never touch places other than those specified. Otherwise, hazardous electric shock or short-circuit can be caused.

There are 2 types of HITACHI PROJECTORS. As shown below, the Control Panel's layout differs from each other. The lower layout allows Static Convergence to be adjusted merely by operating the Remote Control.

□ HITACHI PROJECTOR CONTROL PANEL

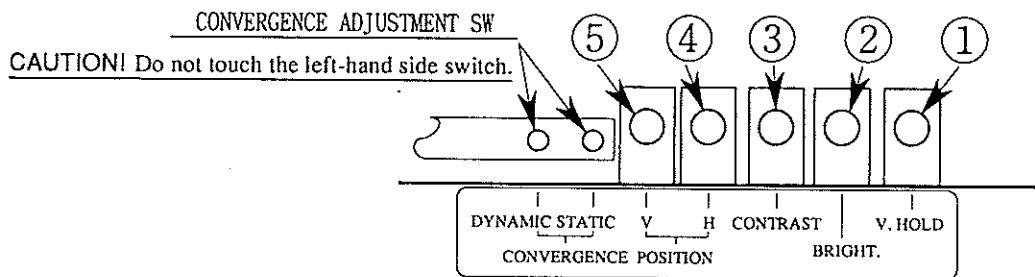
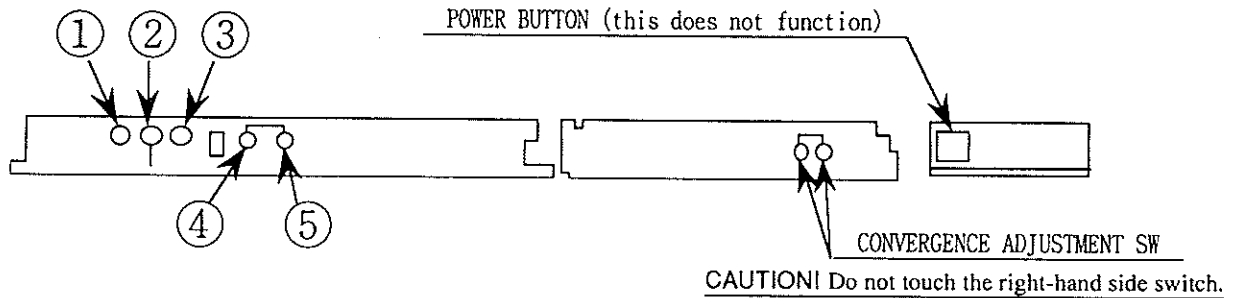

- ① V.HOLD
- ③ CONTRAST
- ⑤ V. POSITION

- ② BRIGHT
- ④ H. POSITION

STATIC CONVERGENCE ADJUSTMENT



IMPORTANT!

Do not touch Dynamic Convergence Adjustment Switch. Although dynamic Convergence adjustment is not needed for this product, should it be pressed by error, turn power off and then turn it back on again.

CROSS PATTERN

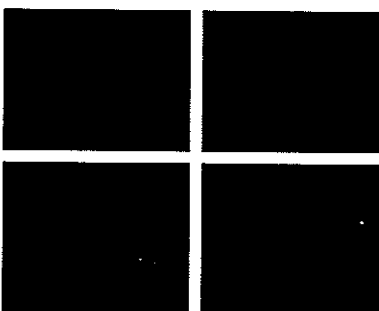

- ① Press the Static Convergence Adjustment SW which is on the Control Panel to cause the cross pattern to appear.
- ② Use the remote control to make static adjustment. For the operation of the Remote Controller, refer to the following pages.
- ③ Press the Static Convergence SW. At this time, static adjustment results are written and the PTV screen will return to the original screen mode.

The Remote Controller has 2 different types. Depending on the specific type, the adjustment procedure varies.

In the case of Remote Controller (Part No. 200-5297):

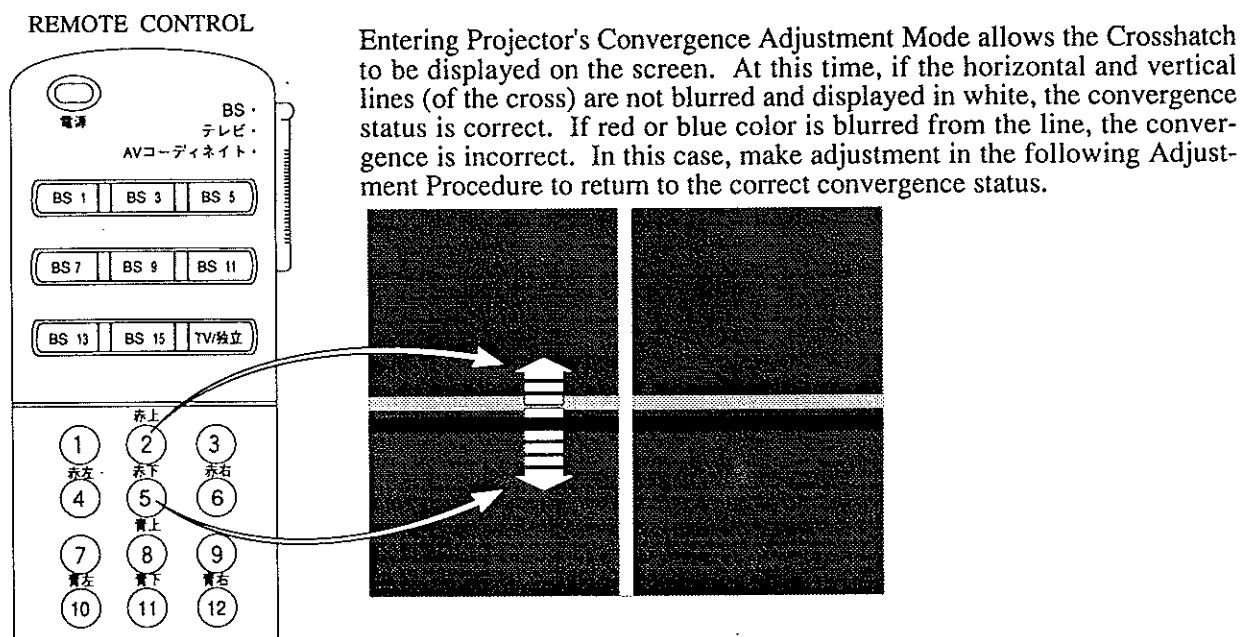

Entering Projector's Convergence Adjustment Mode allows the Crosshatch to be displayed on the screen. At this time, if the horizontal and vertical lines (of the cross) are not blurred and displayed in white, the convergence status is correct. If red or blue color is blurred from the line, the convergence is incorrect. In this case, make adjustment in the following Adjustment Procedure to return to the correct convergence status.

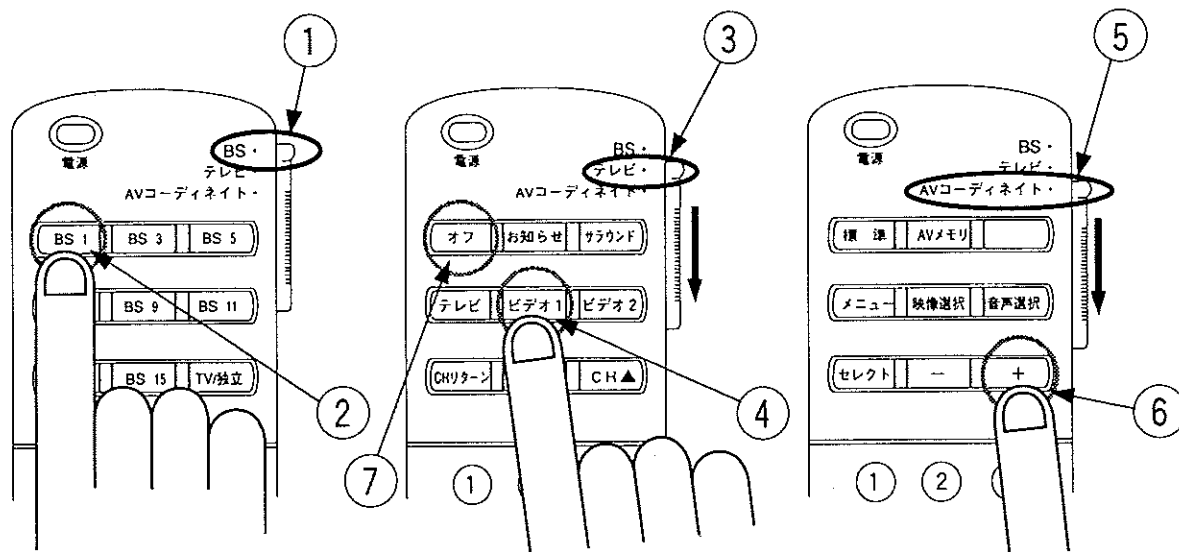

- ① Make sure that the slide portion of the Remote Control is positioned as per ① above.
- ② Press BS1.
- ③ Position the slide portion of the Remote Control to ③ in the above Figure.
- ④ Press VIDEO 1.
- ⑤ Position the Remote Control's slide portion to the above ⑤.
- ⑥ Press "+" to have the cross pattern appear.
- ⑦ Use the remote cotroller to make static adjustment.

Remote control [2], [5] Causes the red horizontal line to match with the green horizontal line.

Remote control [4], [6] Causes the red vertical line to match with the green vertical line.

Remote control [8], [11] Causes the blue horizontal line to match with the green horizontal line.

Remote control [10], [12] Causes the blue vertical line to match with the green vertical line.

- ⑧ Position the Remote Control's slide portion to ③ in the above Figure and push "OFF" 5 times to return to the normal mode.

In the case of Remote Controller (Part No. 200-5410):

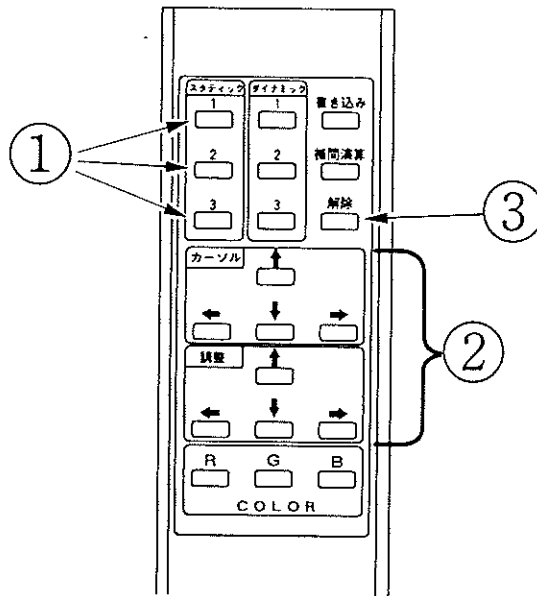
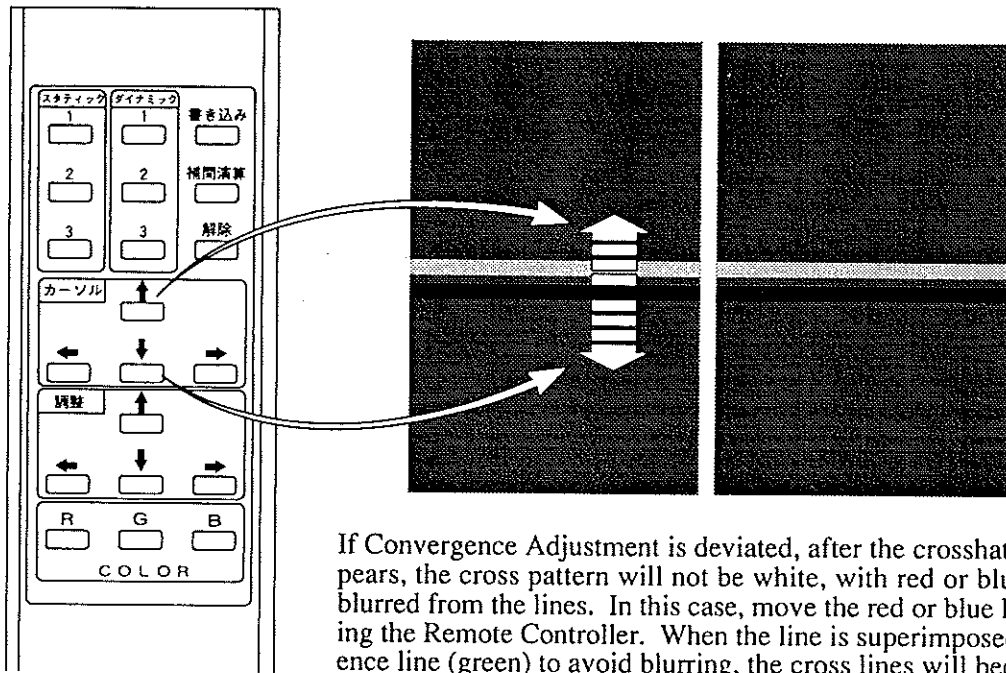

- ① Have the Remote Controller face the Projector screen and press Key 1, 2, and 3 (Portion ① shown) for Static Convergence Adjustment sequentially in order, causing the cross pattern to be displayed.
- ② Press the following arrow keys (Portion ② shown) to make adjustments.
 - Cursor $\uparrow\downarrow$ Causes the red horizontal line to match with the green horizontal line.
 - Cursor $\rightarrow\leftarrow$ Causes the red vertical line to match with the green vertical line.
 - Adjustment $\uparrow\downarrow$ Causes the Blue horizontal line to match with the green horizontal line.
 - Adjustment $\rightarrow\leftarrow$ Causes the Blue vertical line to match with the green vertical line.
- ③ Press the CANCEL Key (Portion ③ shown) 5 times. This operation allows for returning to the original screen and at the same time storing the adjustment data.

12-3 MITSUBISHI PROJECTOR

□ MITSUBISHI PROJECTOR CONTROL PANEL

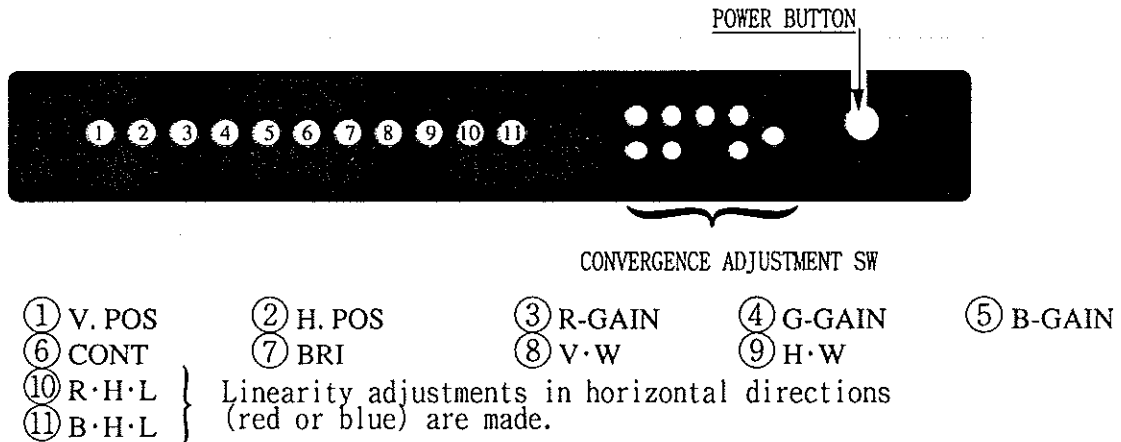

STATIC CONVERGENCE ADJUSTMENT

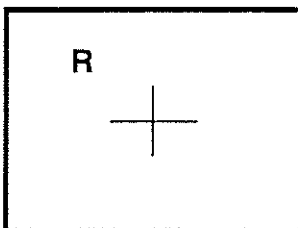
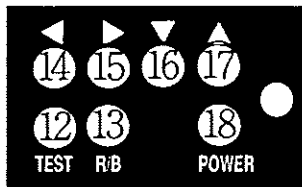

- | | |
|---------|----------------------|
| ⑫ TEST | Test mode on/off key |
| ⑬ R/B | R/B shift key |
| ⑭ ◀ | Left shift key |
| ⑮ ▶ | Right shift key |
| ⑯ ▼ | Lower shift key |
| ⑰ ▲ | Upper shift key |
| ⑱ POWER | Power button |

- ① For the Convergence adjustment mode, press the test mode on/off key ⑫.
- ② Ensure that "R" is displayed on the screen.
- ③ Make adjustment so as to cause the red cross pattern to match with the green cross pattern by using Left Shift key ⑭, Right shift key ⑮, Lower shift key ⑯ and Upper shift key ⑰.
- ④ By using R/B shift key ⑬, cause the red adjustment "R" to shift to blue adjustment "B" and make sure that "B" is displayed on the screen.
- ⑤ In the same manner as in ③ above, cause the blue cross pattern to match with the green cross pattern.
- ⑥ After making adjustment, press the test mode on/off key ⑫ to cancel the Convergence adjustment mode.

STATIC CONVERGENCE ADJUSTMENT WITH REMOTE CONTROL



- Although Remote Control Buttons other than those specified below do not function even if pressed during Convergence Adjustment, do not press them during adjustment work so as to avoid causing malfunctioning.
- Operate the Remote Control towards the PTV screen. If directed other than to the PTV screen, the Remote Control does not function.

BEFORE USING THE REMOTE CONTROL:

First make sure that the main SW on the Projector's control panel is ON (the LED adjacent to the main SW is lit).

- ① For the Convergence Adjustment mode, press the test button (Figures 1·5 below). Ensure that "R" is displayed on the screen.
- ② Make adjustment so as to cause the red cross pattern to match with the green cross pattern. When the red cross matches the green cross, the green cross turns yellow or white (Figures 2·3·4 below).

Use remote control buttons shown below to move the red cross as follows:

- Button ⑤ to the left.
 ⑦ to the right.
 ② Upward.
 ⑩ Downward.

- ③ Use Remote Control button ⑥ to shift "R" to "B." Make sure that "B" is displayed on the screen. Each time Button ⑥ is pressed, red and blue adjustments are shifted.
- ④ In the same manner as in ② above, cause the blue cross to match with the green cross. When the blue cross matches with the green cross, the green cross turns white.
- ⑤ After adjustment is made, press the test button (Figures 1·5 below) to cancel the Convergence Adjustment mode.

※ When 2 minutes or more elapses in the Convergence mode screen without taking any action, the on-screen adjustment mode will disappear.

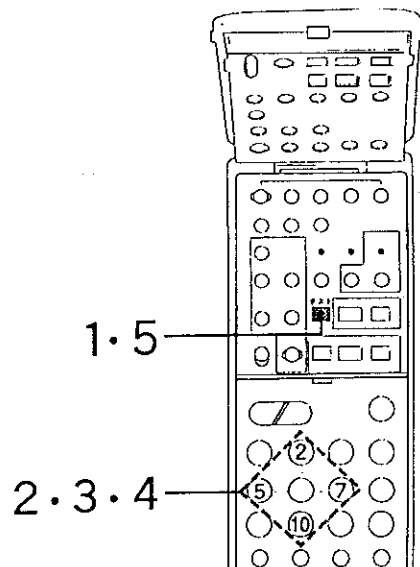
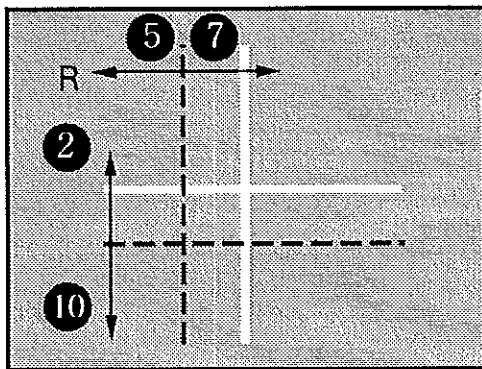

13. REPLACEMENT OF FLUORESCENT LAMP, AND LAMPS



- When performing the work, be sure to turn power off. Working with power on can cause an electric shock or short circuit accident.
- Be sure to use lamps rated as specified. Using lamps not rated as specified can cause a fire or malfunctioning.
- Hot fluorescent lamp and lamps can cause burns. Be very careful when replacing them.

Remove the Billboard Holder and pull out the Billboard upward to replace the Fluorescent Lamp, and Lamps.

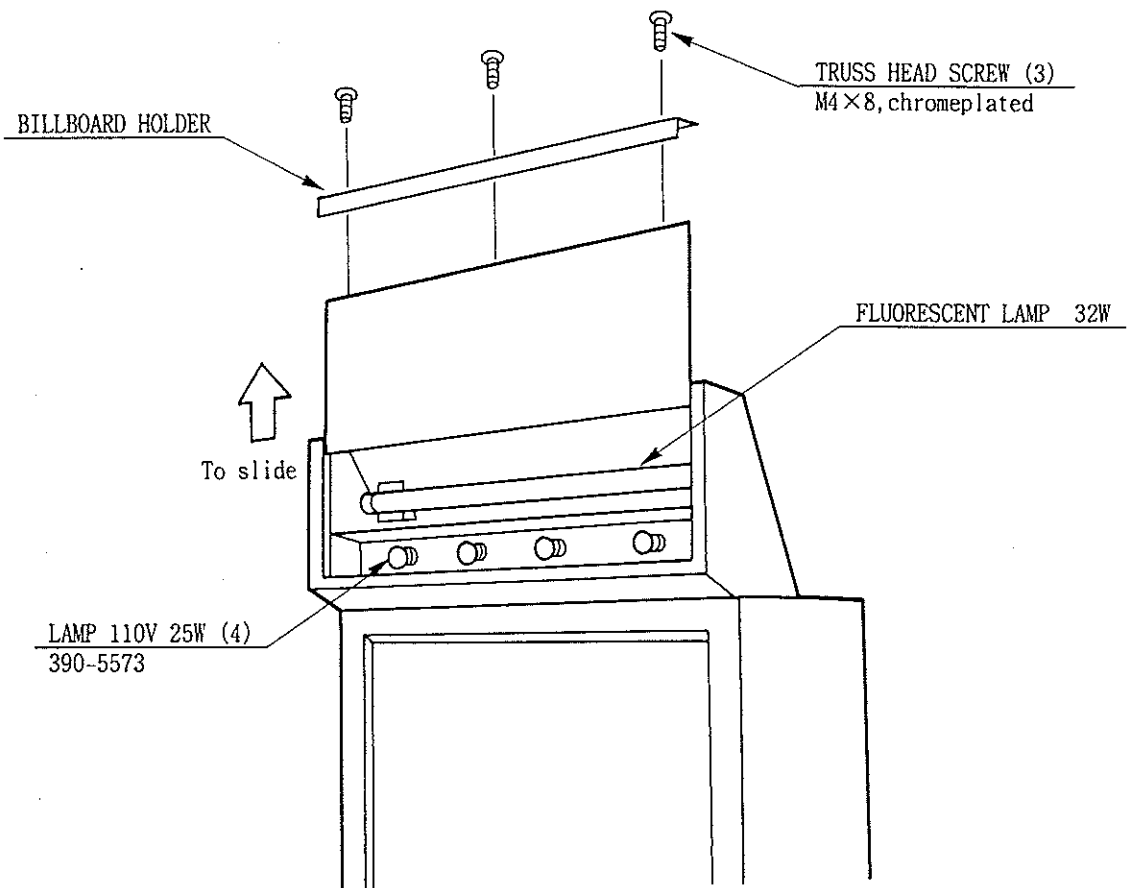

FIG. 13

14. PERIODIC INSPECTION TABLE

The items listed below require periodic check and maintenance to retain the performance of this machine and to ensure safe business operation.



- Be sure to check once a year to see if Power Cords are damaged, the plug is securely inserted, dust is accumulated between the Socket Outlet and the Power Plug, etc. Using the product with dust as is accumulated can cause a fire or electric shock.
- Periodically once a year, request the place of contact herein stated or the Distributor, etc. where the product was purchased from, as regards the interior cleaning. Using the product with dust as is accumulated in the interior without cleaning can cause a fire or accident. Note that cleaning the interior parts can be performed on a pay-basis.

TABLE 14

ITEMS	DESCRIPTION	PERIOD	REFERENCE
HANDLE MECHA	Check VOLUME VALUE.	Monthly	8-4, 9-1
	Check SW.	Monthly	8-4
	Check ADJUST GEAR engagement.	Tri-monthly	9-1
	Greasing to gear portion.	Semi-yearly	9-3
REAR BASE	Check VOLUME VALUE.	Monthly	8-4, 10-1
	Check ADJUST GEAR engagement.	Tri-monthly	10-1
	Greasing to gear portion.	Semi-yearly	10-1
	Inspection of Pinion Gear.	Semi-yearly	10-2
	Greasing to Pinion Gear and Linear Guide.	Semi-yearly	10-3
COIN CHUTE TOWER	Check COIN SWes.	Monthly	8-4
	Coin insertion test.	Monthly	11
	COIN SELECTOR cleaning.	Tri-monthly	11
PROJECTOR	Check adjustments.	Monthly	8, 12
	SCREEN cleaning.	Weekly	12-1
POWER PLUG	Inspection and cleaning	Annually	See above.
INTERIOR	Cleaning		
Cabinet surfaces	Cleaning	As occasion arises.	See below.

CLEANING THE CABINET SURFACES

If the Cabinet is badly stained, use a cloth which is dipped in the chemical detergent liquid diluted with water and then squeezed dry. Do not use thinner, benzine, alcohol or chemical dustcloth as they can damage the Cabinet surfaces.

15. TROUBLESHOOTING



- In order to prevent an electric shock, be sure to turn power off before performing work by touching the interior parts of the product.
- Be careful so as not to cause damage to wirings. Damaged wiring can cause an electric shock or short circuit accident.

For troubleshooting, first check the connection of wiring connectors.

TABLE 15

PROBLEMS	CAUSE	COUNTERMEASURES
When the main SW is turned ON, the machine is not activated.	The power is not ON. Incorrect power source/voltage. The CIRCUIT PROTECTOR functioned due to momentary overcurrent.	Firmly insert the plug into the outlet. Make sure that the power supply/voltage are correct. Remove the cause of overload to reset the circuit protector (see Sec. 6).
Although sound is emitted, PTV screen is blackened and Fluorescent lamp does not light up.	Poor connection of connector between Front Cabinet and PTV.	Check for connection of 3p white connector. (See Section 6.)
Although sound from the Speaker can be faintly heard, PTV screen is completely blackened and the Fluorescent Lamp does not light up.	The Power Supply Unit fuse is blown due to instantaneous overload.	After eliminating the cause of overload, replace the Power Supply Unit fuse. 514-5036-7000 FUSE 6.4 ϕ \times 30 7000mA 125V
The color on the PTV screen is not correct.	Poor connection of connector between Front Cabinet and PTV. Screen adjustment is not appropriate.	Check if R. G. B. and SYNC Connectors are correctly connected. (See Section 6.) Make adjustment appropriately. (See Section 12.)

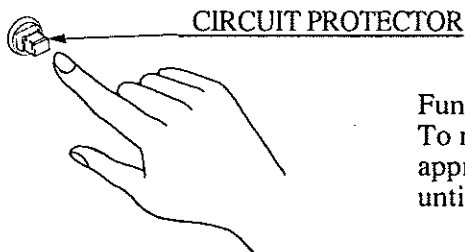

Functions due to the activation of bimetal. To restore the function, wait for approximately one minute or longer until the bimetal cools off. (Press the Button.)

REPLACEMENT AND ADJUSTMENT OF FUSE



- Be sure to use fuses meeting specified rating. Using fuses exceeding the specified rating can cause a fire or electric shock.

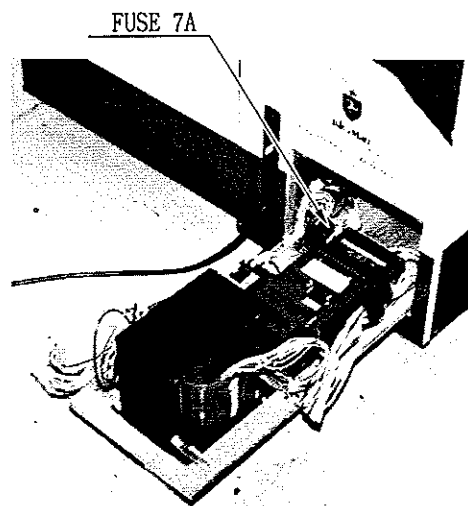

The Power Supply Unit is located inside the Maintenance Lid beside the AC Unit. Disconnect all the Connectors connected to the Power Supply Unit, take out the 2 screws and withdraw the Power Supply Unit. The fuse is contained in the Power Supply Unit.

PROBLEMS	CAUSE	COUNTERMEASURES
PTV screen has a color deviation.	Affected by the periphery, such as other machines, location building's steel frames, etc.	Make convergence adjustments (see Sec. 12). Change installation direction/ position. Move the other machines which cause the problem.
HANDLE MECHA and bike body operation is not satisfactory.	Poor V. R. setting. V. R. deviation or malfunctioning. Poor mesh of ADJUST GEAR. Spring fault due to the secular change of Throttle & Brake Mechanism.	Perform V. R. setting. (See Section 8.) Adjust or replace the V. R. (See Sections 9 & 10.) Adjust ADJUST GEAR mesh. (See Sections 9 & 10.) Replace the Spring.
With MANUAL transmission, shift operation is not satisfactory.	Shift SW malfunctioning.	SW replacement.
During game, no bike body reaction, and irregular functioning. Game start does not unlock the bike.	POWER ON check is not satisfactory. Poor connection or malfunctioning of Motor Driver and Drive BD. Overheat of motor.	Redo power input and complete POWER ON check (see Sec. 6). Perform Drive BD test (see Sec. 8). Check for connection between Motor, Motor Driver, Driver BD and Game BD. Wait for a while and turn power back on again.
Bike body centering is incorrect.	V. R. setting fault. V. R. deviation or malfunctioning	Perform V. R. setting (see Sec. 8). Adjust or replace the V. R. (see Sec. 10).
Irregular sound is emitted from inside the Rear Base.	Poor mesh of mechanism gear inside Rear Base. Greasing to gear mesh portion is not satisfactory, or extraneous matter mixed in.	Adjust gear mesh (see Sec. 10). Apply greasing or eliminate extraneous matter (see Sec. 10).
Bike body is not locked.	Wing Bolts for maintenance are not removed.	Remove the Wing Bolts (see Sec. 10).
Leader Lamp or Fluorescent Lamp does not light up.	Poor connection of connector between Front Cabinet and PTV. Poor connection of connector in the Billboard. Lamp and Fluorescent lamp need replacement.	Accurately connect 4p white connector (see Sec. 6). Accurately connect the Connector (see Sec. 6). Replace Lamp and Fluorescent Lamp (see Sec. 13).
Sound is not emitted.	Poor connection of connector between Front Cabinet and Rear Base. Sound volume is incorrect. Sound related Board and Memory are irregular.	Accurately connect the connector (see Sec. 6). Adjust the Sound Volume Adjustment V. R. of the SW Unit (see Sec. 8). Perform sound test (see Sec. 8).

16. GAME BOARD



- In order to prevent an electric shock, be sure to turn power off before performing work by touching the interior parts of the product.
- Be careful so as not to cause damage to wirings. Damaged wiring can cause an electric shock or short circuit accident.



Do not expose the Game BD, etc. without a good reason. In this product, setting changes are made during the test mode. The Game BD need not be operated. Use the Game BD, etc. as is with the same setting made at the time of shipment.

16-1 TAKING OUT THE GAME BD.

When replacing or inspecting the Game BD, take out the Game BD by using the following procedure.

- ① Turn the AC Unit's Main SW OFF.
- ② Remove the 2 Truss Screws (black) from the upper face of the Front Cabinet, unlock with the Master Key to open the Service Lid (refer to FIG. 6. 2 c).
- ③ Take out the 2 screws shown to remove a total of 6 Connectors.
- ④ Hold the catch of the Shield Case Base and pull out upward.
- ⑤ Take out the 3 screws to remove the Case Lid from the Shield Case. The Game Board can be viewed.

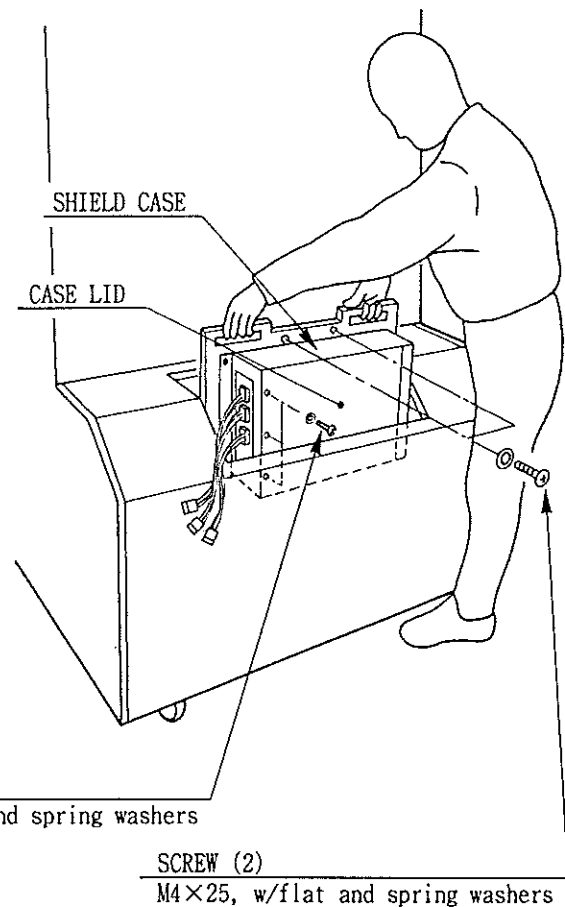

FIG. 16. 1

16-2 COMPOSITION OF GAME BOARD

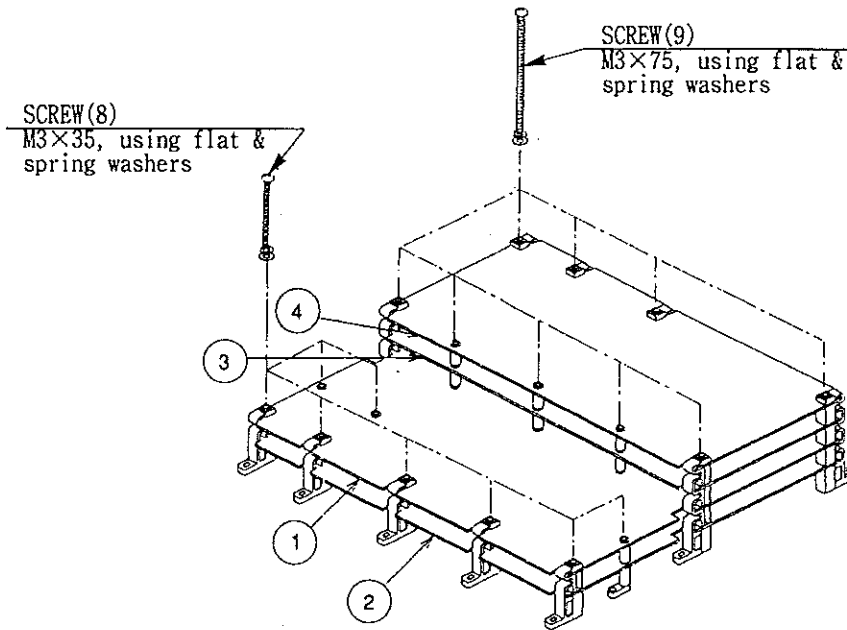
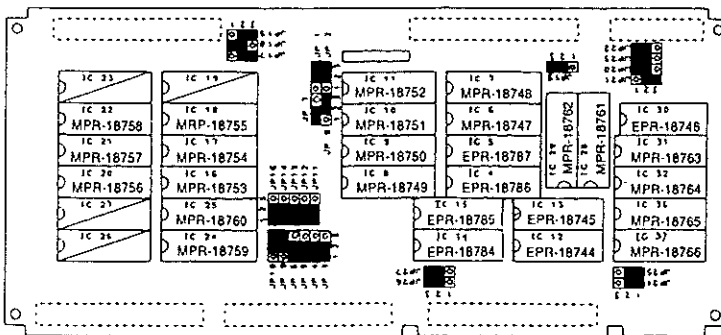

FIG. 16.2

No.	PART No.	DESCRIPTION
1	837-10848-01-91	MODEL2 A-CRX CPU BD COM
2	837-10849-02	MODEL2 A-CRX VIDEO BD COM
3	837-12396	COMM BD MANX T.T
4	834-12277	ROM BD MANX T.T DX

口△配置図



ROM BD MANX T.T DX (834-12277)

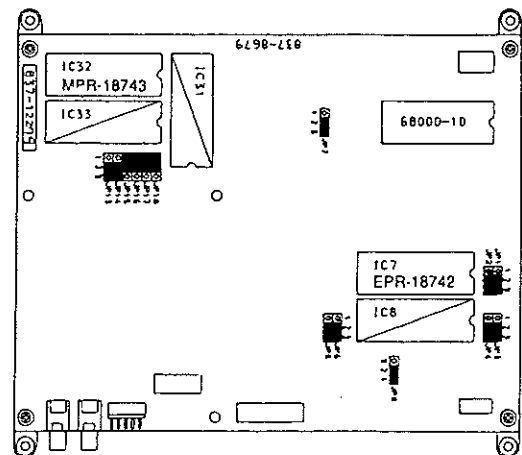

SOUND BD MANX T.T (837-12279)

17. DESIGN RELATED PARTS

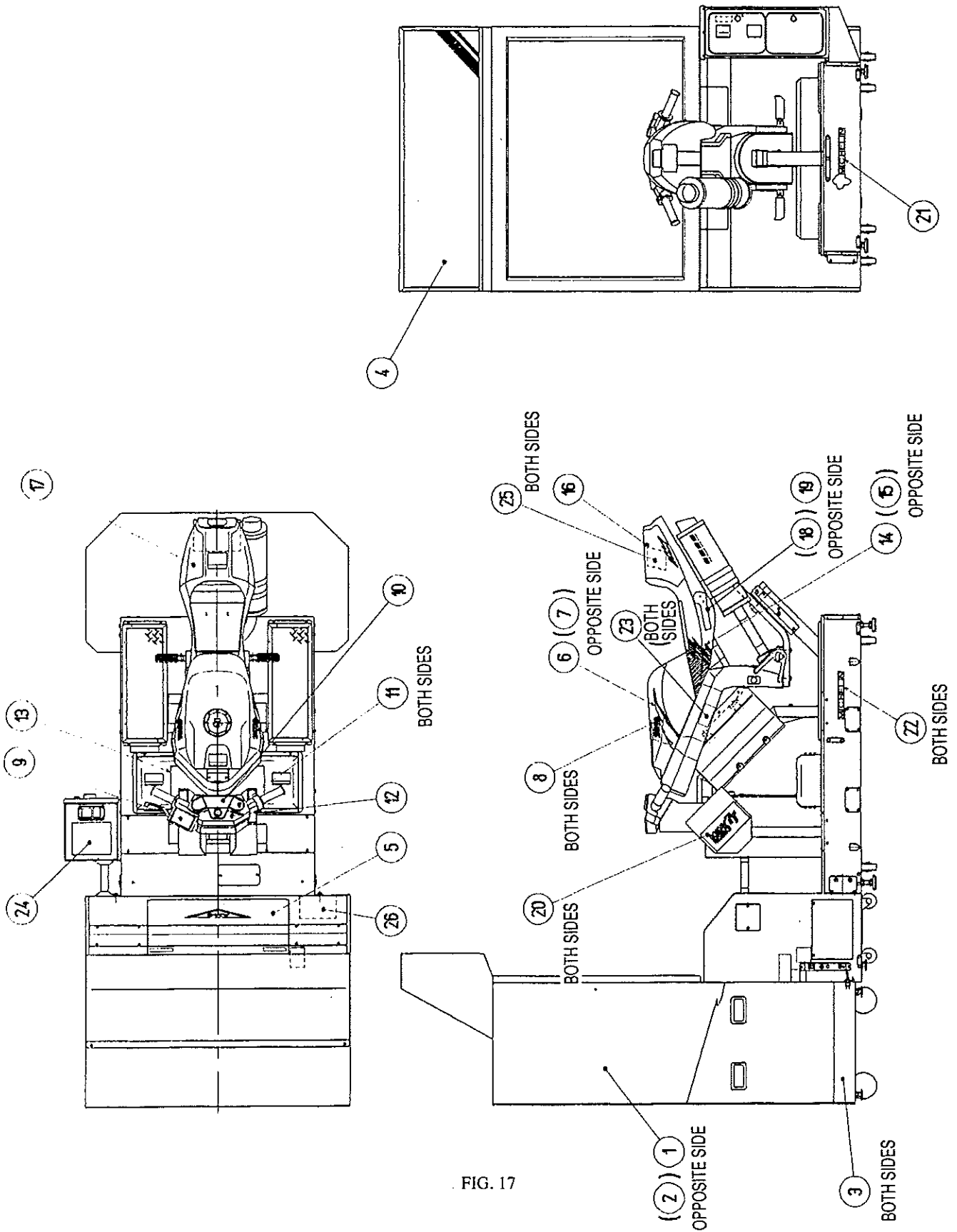

FIG. 17

1	421-9011	STICKER SIDE TV L TTR
2	421-9012	STICKER SIDE TV R TTR
3	421-9013	STICKER SIDE TV LOWER TTR
4	TTR-0551	BILLBOARD
5	TTR-1021-A	STICKER SERVICE LID
6	TTR-3001-B	STICKER TANK LINE L
7	TTR-3001-C	STICKER TANK LINE R
8	TTR-3001-D	STICKER SEGA LOGO STM30
9	TTR-3003-B	STICKER BRAKE
10	TTR-3004-B	STICKER START
11	TTR-3004-C	STICKER TOP BRIDGE
12	TTR-3004-D	STICKER CARBON
13	TTR-3033-A	STICKER ISLE OF MAN
14	TTR-3051-C	STICKER SEAT LINE L
15	TTR-3051-D	STICKER SEAT LINE R
16	TTR-3051-E	STICKER NO. BASE L
17	TTR-3051-F	STICKER NO. BASE R
18	TTR-3051-G	STICKER SEAT COWL SPO A
19	TTR-3051-H	STICKER SEAT COWL SPO B
20	TTR-3082-A	STICKER MANX LOGO
21	TTR-3101-C	STICKER REAR CABI SPO L
22	TTR-3101-D	STICKER REAR CABI SPO R
23	TTR-0005	STICKER AMS
24	422-0560-01	PLAY INSTR SH TTR DX ENG
25	421-9008	STICKER TTR No. 1~8
26	421-9014	STICKER FRONT No. 1~8

18. PARTS LIST

① TOP ASSY MANX T.T DX

(D-1/3)

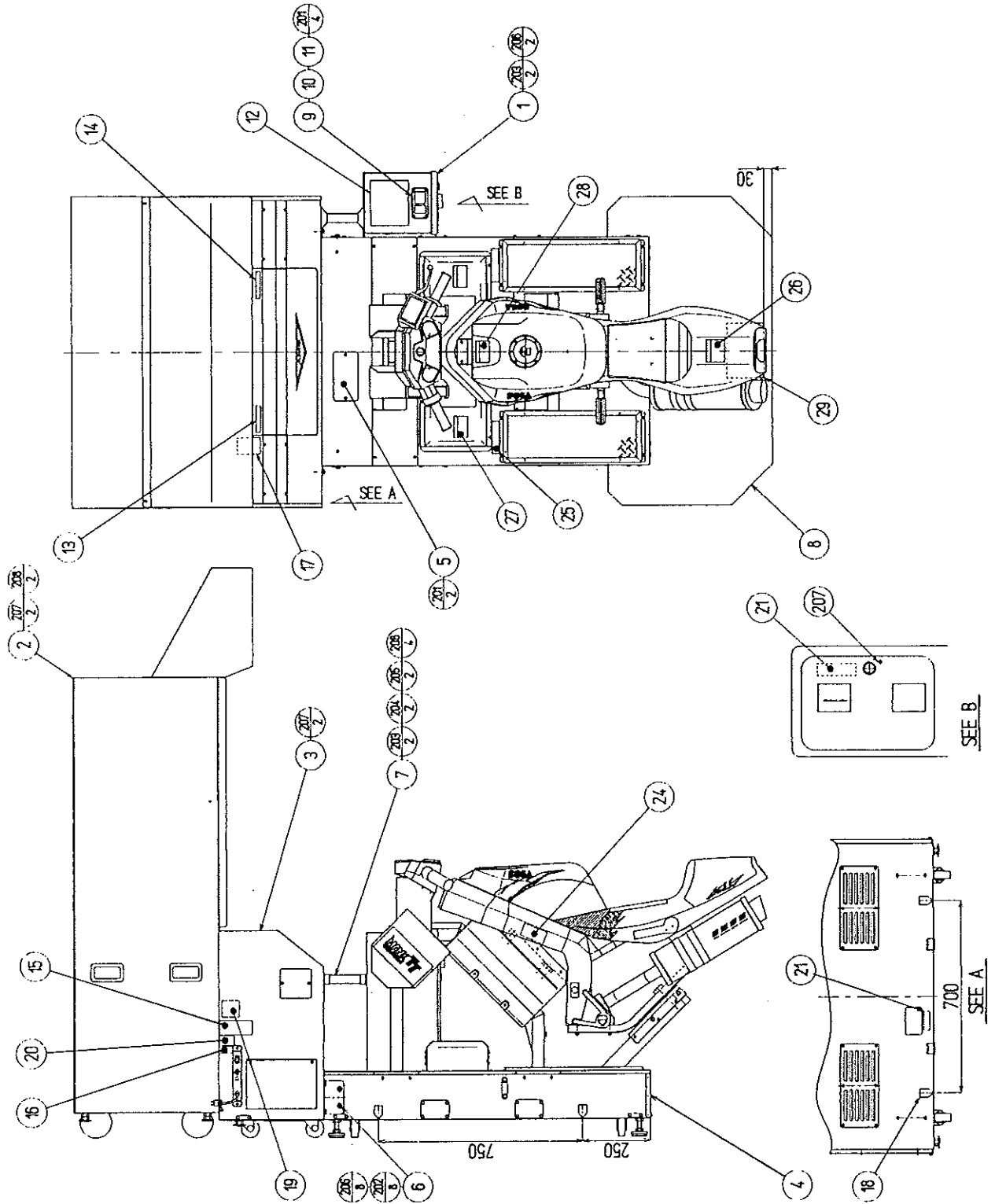

① TOP ASSY MANX T. T DX

(D-2/3)

ITEM NO.	PART NO.	DESCRIPTION	NOTE
1	TTR-0100	ASSY COIN CHUTE TOWER	
2	TTR-0500	ASSY PTV	
3	TTR-1000	ASSY FRONT CABINET	
4	TTR-3000	ASSY REAR BASE	
5	TTR-0001	HOLE LID	
6	TTR-0002	JOINT PLATE	
7	TTR-0003	TOWER SUPPORT	
8	TTR-0004	SAFETY MAT	
9	DYN-0010	DENOMI PLATE	
11	421-7308~	DENOMINATION SHEET 1 GAME ~	
12	422-0560-01	PLAY INSTR SH TTR DX ENG	
16	421-6594-91	STICKER CERTIFICATE	
17	440-WS0033-EG	STICKER W BD POWER OFF ENG	
18	421-7020	STICKER CAUTION FORK	
19	421-7987	STICKER ELEC SPEC	OTHERS
	421-8408	STICKER ELEC SPEC FOR TAIWAN	TAIWAN
21	421-7988-91	STICKER SERIAL NUMBER	
22	SGM-4390	POLY COVER 1150×400×650	
23	SGM-4391	AIR CAP COVER 1100×1800×900	
24	TTR-0005	STICKER AMS	
25	TTR-0006-01	STICKER FOOT MAT TTR ENG	
26	440-WS0040-EG	STICKER W TTR A ENG	
27	440-WS0041-EG	STICKER W TTR B ENG	
28	440-WS0042-EG	STICKER W/TTR C ENG	
29	440-WP0045-EG	PLATE W TTR D ENG	
201	000-T00408-0B	M SCR TH BLK M4×8	
202	030-000830-SB	HEX BLT W/S BLK M8×30	
203	030-000816-SB	HEX BLT W/S BLK M8×16	
204	050-H00800	HEX NUT M8	
205	060-S00800	SPR WSHR M8	
206	060-F00800-0B	FLT WSHR BLK M8	
207	000-T00430-0B	M SCR TH BLK M4×30	
208	068-441616	FLT WSHR 4.4-16×1.6	
401	601-6604-70	CARTON BOX 70	
402	420-6207-01	OWNERS MANUAL MANX T. T. DX ENG	
403	SGM-2675	POLYETHYLENE BAG 240×370	
404	220-5381	KEY MASTER FOR 220-5380	
405	SGM-4111	KEY BAG	
408	220-5373	VOL CONT B-5K OHM	
	220-5484	VOL CONT B-5K OHM	
409	421-9008	STICKER TTR No. 1~8	
410	514-5036-7000	FUSE 6.4φ×30 7000mA 125V	
411	509-0161	PUSH BUTTON SWITCH 1T YELLOW W/LAMP	
413	032-000416	WING BLT M4×16	
414	421-9014	STICKER FRONT No.1~8	
415	TTR-0022	GUARD PIPE	
416	601-8569-YE128	PLASTIC CHAIN YB-128	
417	601-8618	SPRING HOOK φ4.5	
418	030-000830-SB	HEX BLT W/S BLK M8×30	
419	068-852216-0B	FLT WSHR BLK 8.5-22×1.6	

① TOP ASSY MANX T.T DX

(D-3/3)

ITEM NO.	PART NO.	DESCRIPTION	NOTE
/	GPD-0002X	SHIPPING BRACKET	
/	421-6690~	STICKER~V	
/	600-6618	AC CABLE CONNECT TYPE FOR EXP	AC 220~240V AREA
/	600-6619	AC CABLE CONNECT TYPE FOR UK	UK
/	421-6119-91	STICKER FCC	} USA
/	421-6120-91	STICKER SEGA USA	

② ASSY COIN CHUTE TOWER (TTR-0100)

(D-1/2)

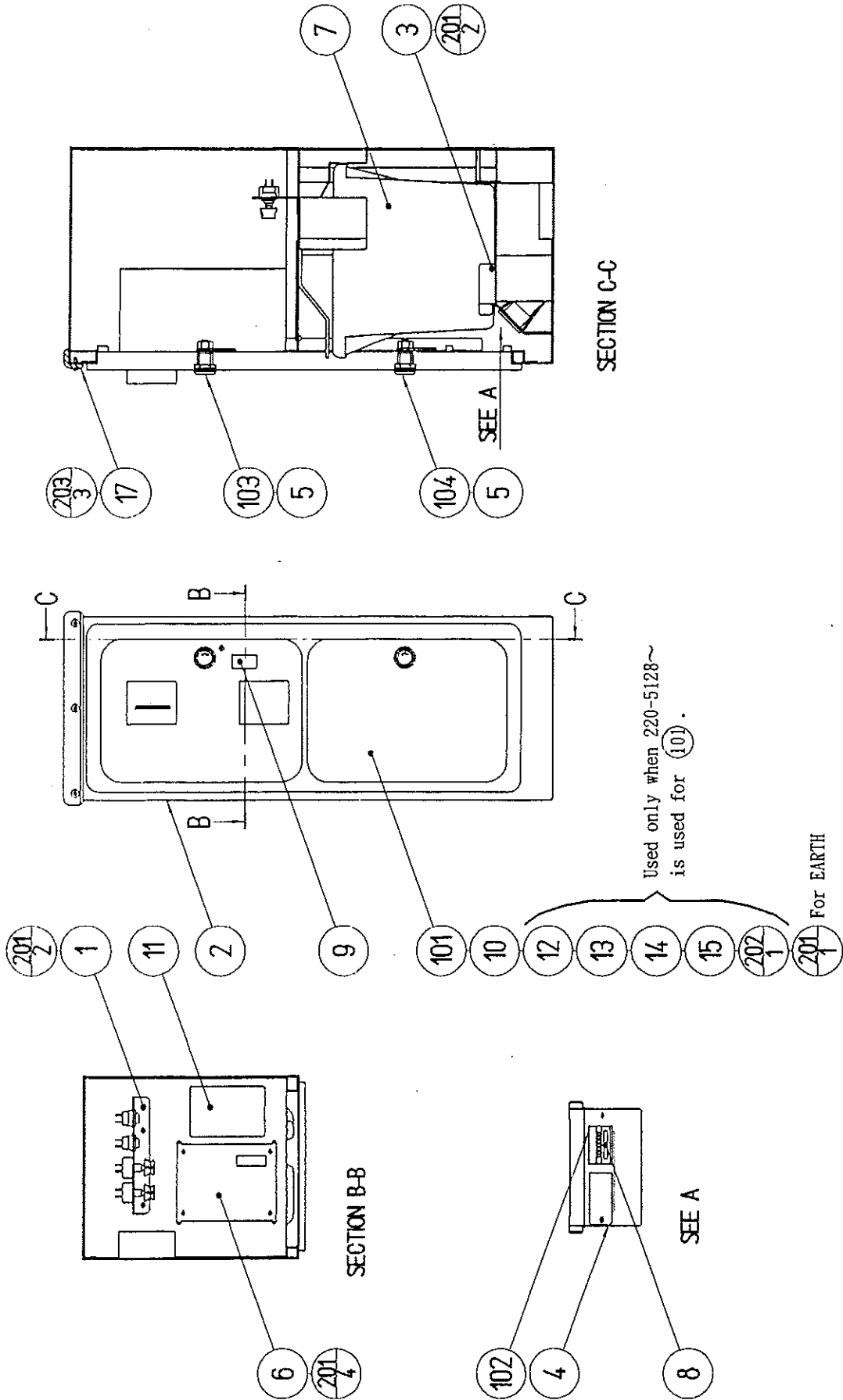

② ASSY COIN CHUTE TOWER (TTR-0100)

(D-2/2)

ITEM NO.	PART NO.	DESCRIPTION	NOTE
1	TTR-0150	SW UNIT	
2	TTR-0101	COIN CHUTE TOWER	
3	INY-1162	METER BRKT	
4	INY-1163	METER HOLE LID	MARS TYPE
		NOT USED	OTHERS
5	DP-1167	TNG LKG	OTHERS
		NOT USED	MARS TYPE
6	105-5173	CHUTE PLATE MARS	MARS TYPE
	105-5172	CHUTE PLATE DOUBLE	OTHERS
7	253-5366	CASH BOX	
8	421-6591-01	STICKER COIN METER	
10	421-7501-02	STICKER 6.3V 0.15A	OTHERS
		NOT USED	MARS TYPE
11	440-WS0002XEG	STICKER W POWER OFF ENG	OTHERS
12	HN-1050	SPACER RING	OTHERS
		NOT USED	MARS TYPE
14	105-5201	MAGNETIC LOCK BRKT FOR ASAHI	OTHERS
		NOT USED	MARS TYPE
15	109-0045-91	KEY HOLDER	OTHERS
		NOT USED	MARS TYPE
17	TTR-0102	EDGE PAD	
101	220-5128~	ASSY COIN CHUTE 2DOOR ~	OTHERS
	220-5374	DOUBLE DOOR FRAME W/CASH DOOR	MARS TYPE
102	220-5412	MAG CNTR W/CONN	OTHERS
	220-5217-01	MAG CNTR 6DIG DC12V	MARS TYPE
103	220-5380	MAG LOCK MASTER W/O KEY	OTHERS
		NOT USED	MARS TYPE
104	220-5046-91	MAGNETIC LOCK W/KEYS	OTHERS
		NOT USED	MARS TYPE
105	280-5009	CORD CLAMP ϕ 21	
106	310-5029-F20	SUMITUBE F F20MM	
107	601-0460	PLASTIC TIE BELT 100MM	
201	000-P00408-W	M SCR PH W/FS M4 \times 8	
202	000-P00306-W	M SCR PH W/FS M3 \times 6	OTHERS
		NOT USED	MARS TYPE
203	000-T00412-0B	M SCR TH BLK M4 \times 12	
301	600-6659-38	WIRE HARN COINCHUTE TOWER	
302	600-6659-59	WIRE HARN EARTH COINCHUTE	
303	600-6455-01	WIRE HARN COIN CHUTE DOOR TWIN	OTHERS
	600-6609-60	WIRE HARN MS-III	MARS TYPE
/	220-5412-01	MAG CNTR W/CONN BLACK	OTHERS
/	600-6455-06	WIRE HARN METER GND WH	MARS TYPE

③ SW UNIT (TTR-0150)

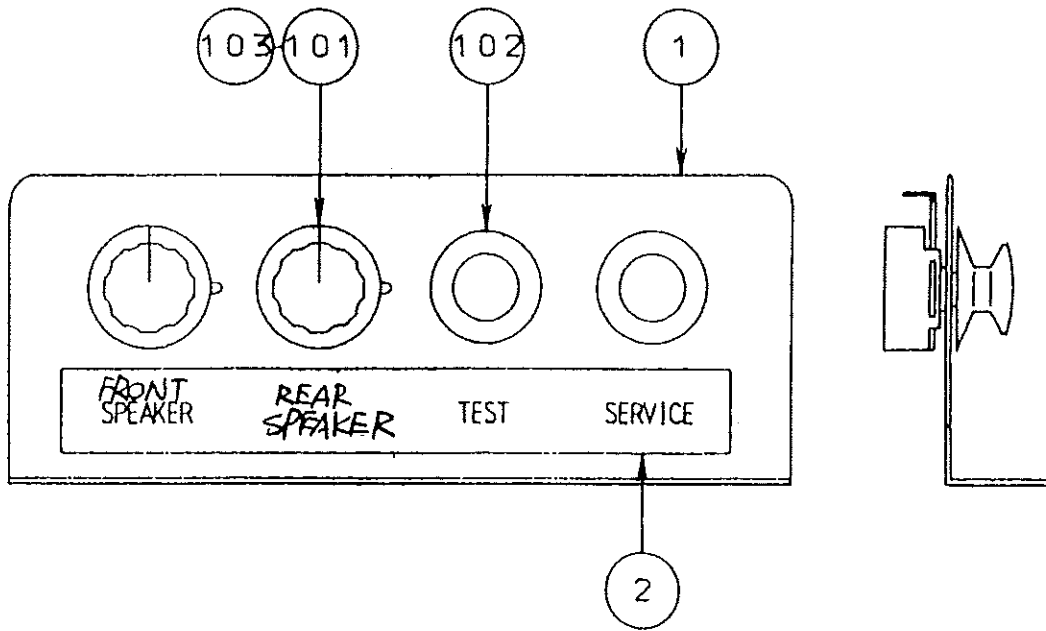

ITEM NO.	PART NO.	DESCRIPTION	NOTE
1	INY-1181	SW BRKT	
2	421-9000	STICKER SW UNIT TTR	
101	220-5179	VOL CONT B-5K OHM	
102	509-5028	SW PB 1M	
103	601-0042	KNOB 22MM	
104	310-5029-F20	SUMITUBE F F20MM	
105	601-0460	PLASTIC TIE BELT 100MM	
301	600-6609-32	WIRE HARN TEST & SERVICE	
302	600-6609-33	WIRE HARN VOLUME A	
303	600-6609-34	WIRE HARN VOLUME B	

④ ASSY PTV (TTR-0500)

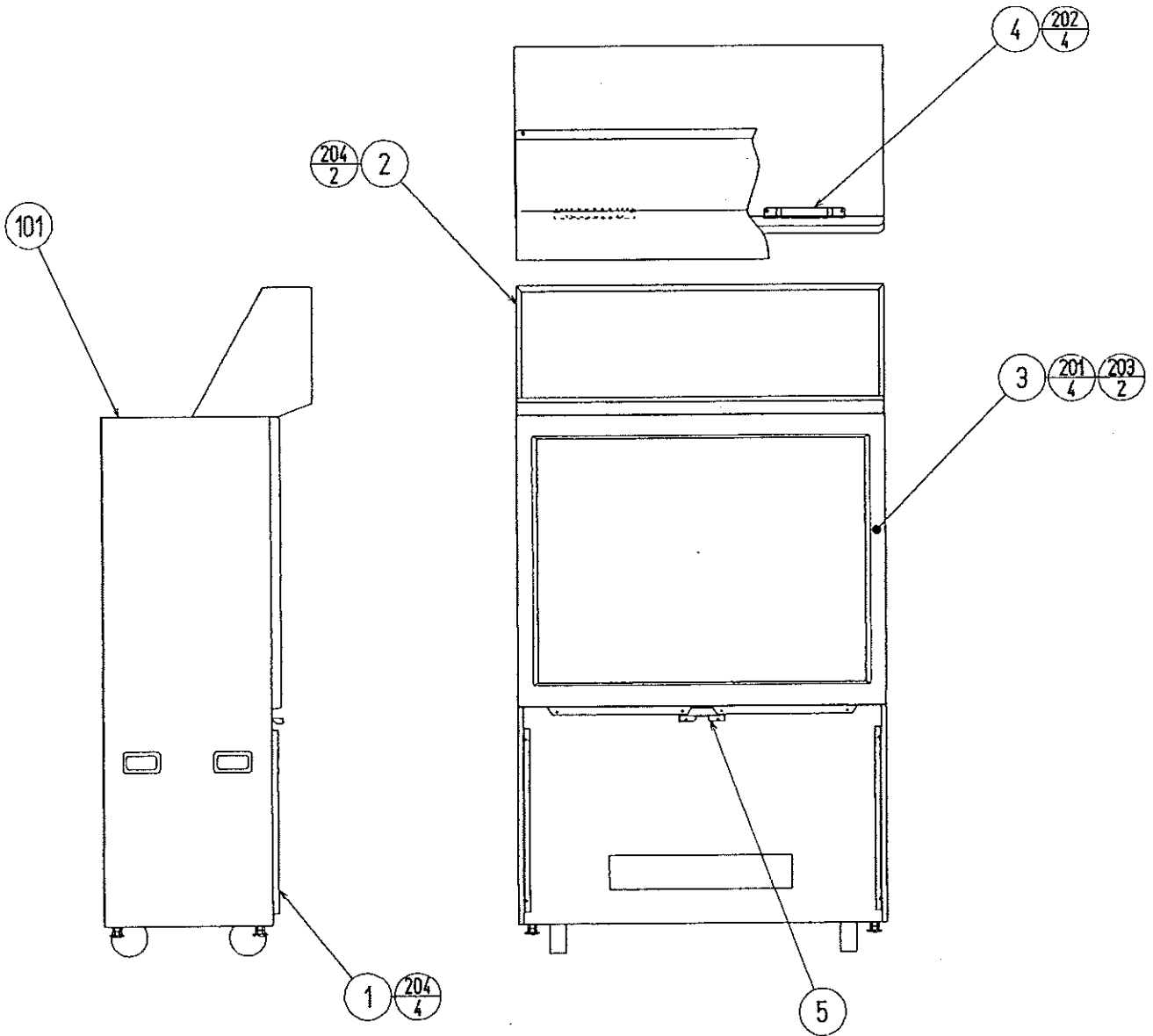

ITEM NO.	PART NO.	DESCRIPTION	NOTE
1	TTR-0501	GUIDE BRKT	
2	TTR-0550	ASSY BILLBOARD	
3	MGL-1150	ASSY MASK	
4	RAL-0501	MASK HOLDER	
5	TTR-0502	LOCK BRKT	
101	220-5315-01-TTR	ASSY PROJECTION DISPLAY TTR(W/RC)	
201	000-T00520-0C	M SCR TH CRM M5×20	
202	000-F00414	M SCR FH M4×14	
203	000-T00525-0C	M SCR TH CRM M5×25	
204	000-P00516-W	M SCR PH W/PS M5×16	

⑤ ASSY BILLBOARD (TTR-0550)

(D-1/2)

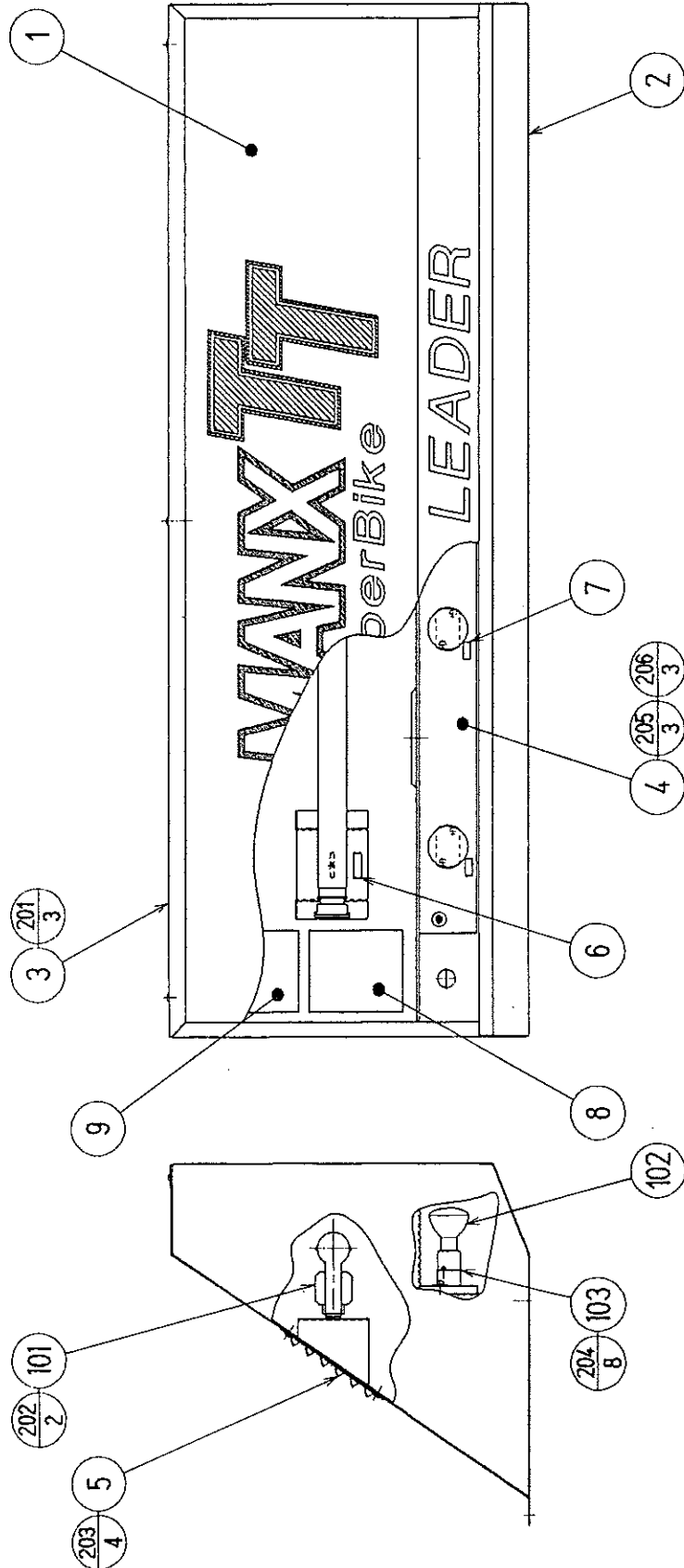

⑤ ASSY BILLBOARD (TTR-0550)

(D-2/2)

ITEM NO.	PART NO.	DESCRIPTION	NOTE
1	TTR-0551	BILLBOARD	
2	TTR-0552	BILLBOARD BOX	
3	TTR-0553	BILLBOARD HOLDER	
4	TTR-0554	LAMP BASE	
5	UP-1018	AIR VENT	
6	421-7501-18	STICKER FL32W	
7	421-7501-01	STICKER 110V 25W	
8	440-WS0002XBG	STICKER W POWER OFF ENG	
9	440-WS0012XBG	STICKER W HIGH TEMP ENG	
101	390-5538-32EX	ASSY FL32W EX W/CONN HIGH	
102	390-5573	LAMP 110V 25W	
103	214-0184	LAMP SOCKET E17	
104	280-5009	CORD CLAMP ϕ 21	
105	601-0460	PLASTIC TIE BELT 100MM	
106	280-5008	CORD CLAMP ϕ 15	
201	000-T00408-0C	M SCR TH CRM M4 \times 8	
202	000-P00416-W	M SCR PH W/FS M4 \times 16	
203	000-T00408-0B	M SCR TH BLK M4 \times 8	
204	000-P00325-W	M SCR PH W/FS M3 \times 25	
205	000-P00420-S	M SCR PH W/S M4 \times 20	
206	068-441616	FLT WSHR 4, 4-16 \times 1.6	
207	011-P00310	TAP SCR FH 3 \times 10	
301	600-6659-31	WIRE HARN BILLBOARD1	
302	600-6445-46-91	WIRE HARN BILLBOARD	

⑥ ASSY MASK (MGL-1150)

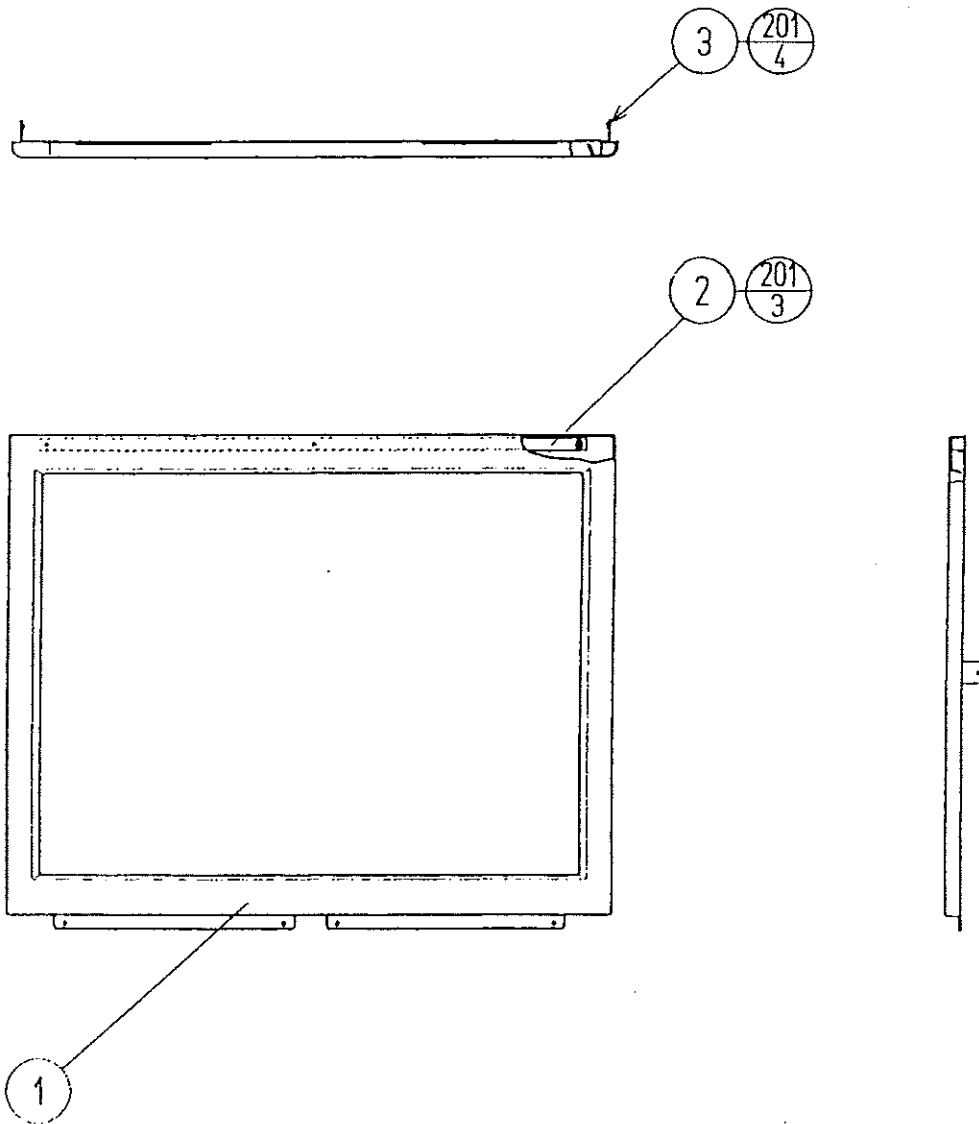

ITEM NO.	PART NO.	DESCRIPTION	NOTE
1	MGL-1102	TV MASK	
2	MGL-1151	SLIT PLATE	
3	MGL-1152	MASK SIDE HOLDER	
201	012-F00408-0B	TAP SCR FH BLK 4×8	
202	000-F00410	M SCR FH M4×10	

⑦ ASSY FRONT CABINET (TTR-1000)

(D-1/2)

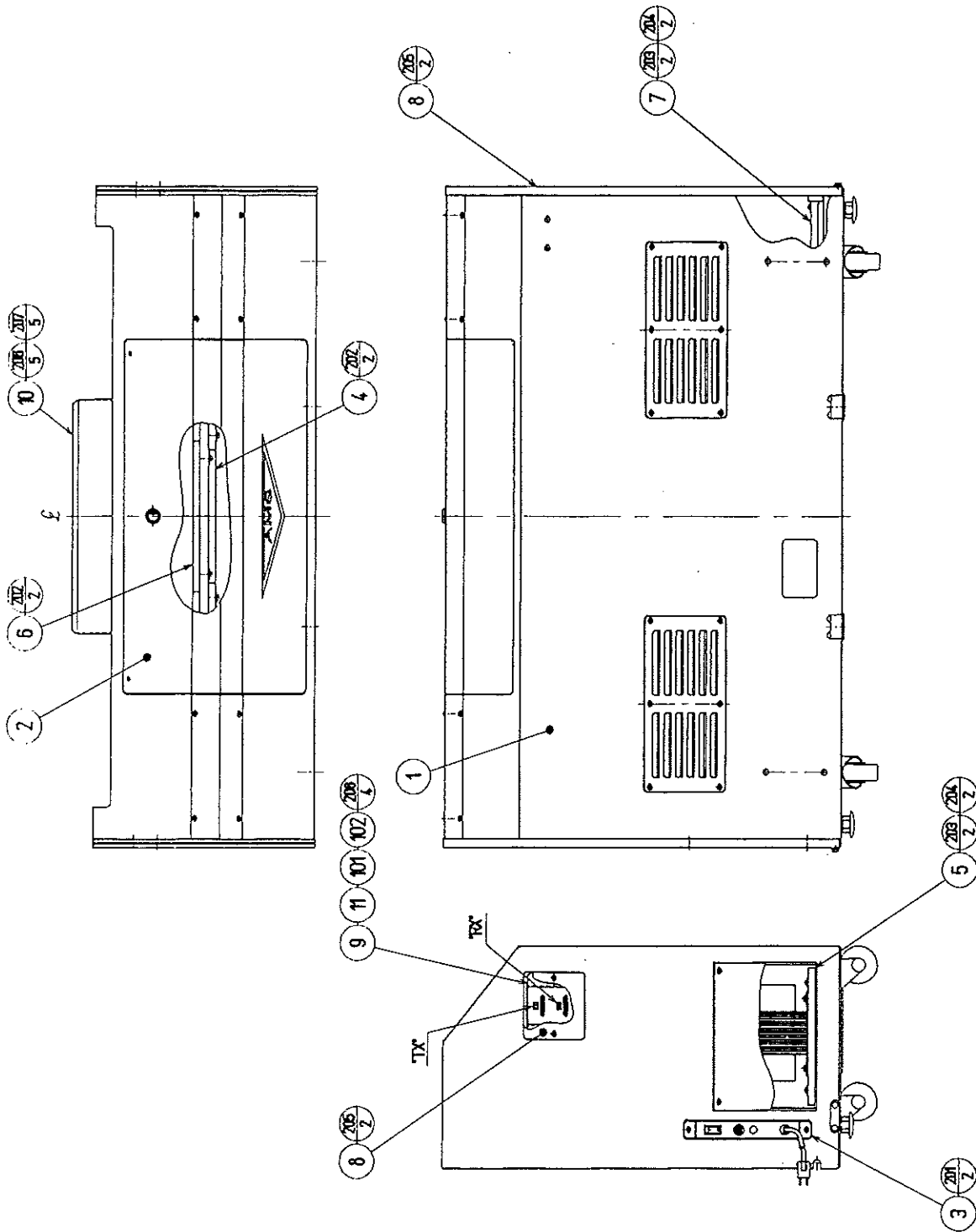

⑦ ASSY FRONT CABINET (TTR-1000)

(D-2/2)

ITEM NO.	PART NO.	DESCRIPTION	NOTE
1	TTR-1001	ASSY SUB FRONT CABINET	
2	TTR-1020	ASSY SERVICE LID	
3	TTR-1030	AC UNIT	AC110~120V AREA
	TTR-1040	AC UNIT EXP	AC220~240V AREA
4	TTR-1100	ASSY SHIELD CASE	
5	TTR-4000	ASSY PWR SPLY	
6	TTR-4100	ASSY SOUND BD BASE	
7	TTR-4200	ASSY DRIVE BD BASE	
8	TTR-1011	OPT CONN LID	
9	TTR-1012	OPT CONN BRKT	
10	TTR-1014	ANTI-LIFT BRKT	
11	421-7515	STICKER FIBER CABLE TX/RX	
101	211-5479	CONN OPT JOINT	
102	600-6275-0150	ASSY FIBER CABLE ϕ 5 0150CM	
201	000-T00416-0B	M SCR TH BLK M4 \times 16	
202	000-P00425-W	M SCR PH W/FS M4 \times 25	
203	000-P00420-S	M SCR PH W/S M4 \times 20	
204	068-441616	FLT WSHR 4. 4-16 \times 1.6	
205	000-T00416-0C	M SCR TH CRM M4 \times 16	
206	030-000620-S	HEX BLT W/S M6 \times 20	
207	060-P00600	FLT WSHR M6	
208	000-P00312-W	M SCR PH W/FS M3 \times 12	
301	600-6659-53	WIRE HARN RGB	

8 ASSY SUB FRONT CABINET (TTR-1001)

(D-1/2)

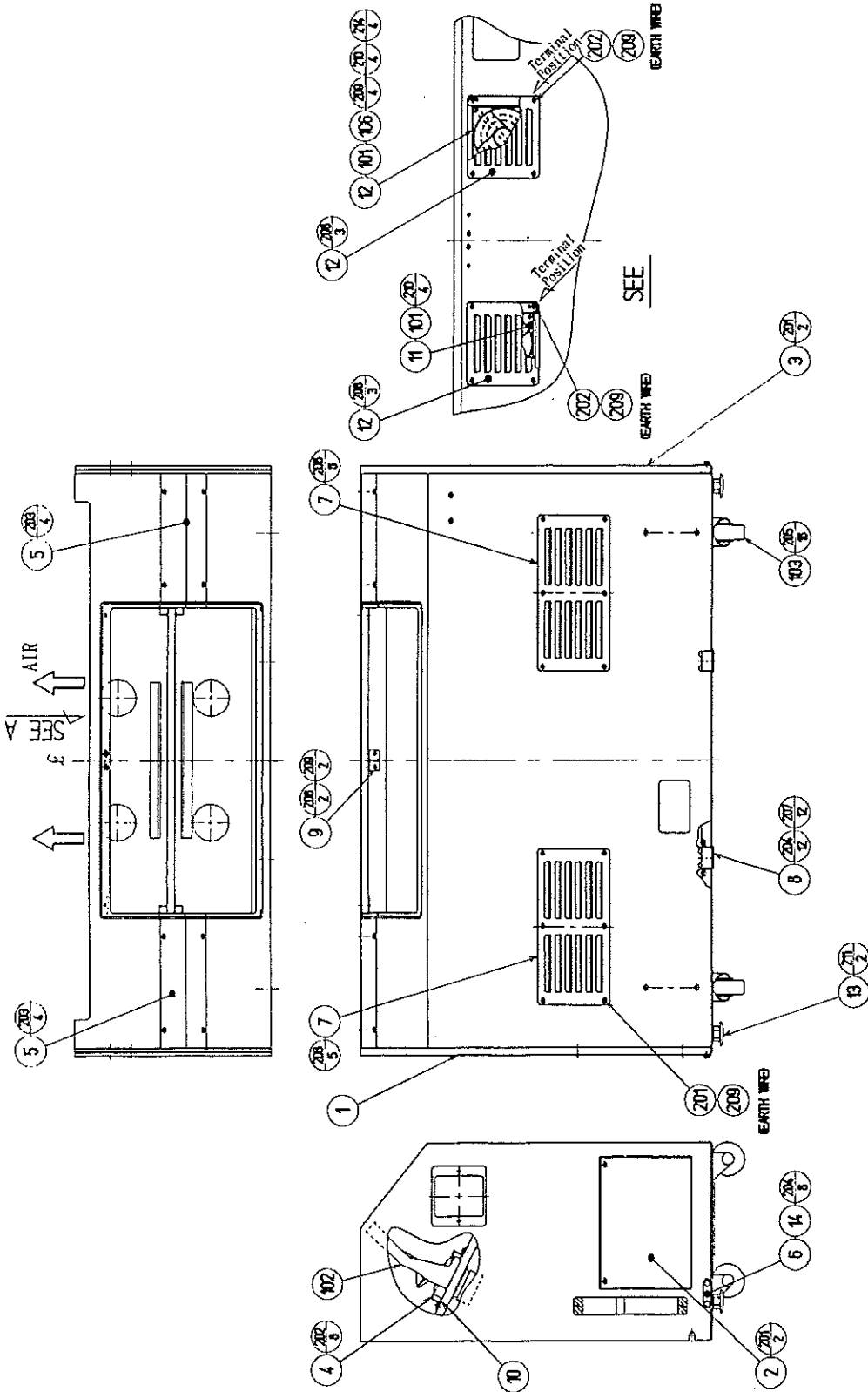

⑧ ASSY SUB FRONT CABINET (TTR-1001)

(D-2/2)

ITEM NO.	PART NO.	DESCRIPTION	NOTE
1	TTR-1002	WOODEN FRONT CABINET	
2	TTR-1003	MAINTENANCE LID L	
3	TTR-1004	MAINTENANCE LID R	
4	TTR-1005	SPEAKER HOLDER	
5	TTR-1006	SPEAKER NET	
6	TTR-1010	LEG BRKT	
7	TTR-1013	TWIN AIR VENT	
8	TTR-1015	CATCH BRKT	
9	TTR-1016	LOCKING BRKT	
10	TTR-1017	RUBBER CUSHION	
11	HN-1042X	FAN BRKT	
12	UP-1018	AIR VENT	
13	601-5699X	LIG ADJUSTER BOLT M16×75	
14	117-5233	PLATE LEG BRACKET BLACK	
101	260-0011-02	AXIAL FLOW FAN AC100V 50-60Hz	
102	130-5140	SPEAKER BOX MINI DOME	
103	601-5471	CASTER	
104	280-5009	CORD CLAMP ϕ 21	
105	280-0419	HARNESS LUG	
106	601-8543	FAN GUARD	
201	000-T00425-0C	M SCR TH CRM M4×25	
202	000-P00425-W	M SCR PH W/FS M4×25	
203	000-T00416-0B	M SCR TH BLK M4×16	
204	030-000625-SB	HEX BLT W/S BLK M6×25	
205	030-000825-S	HEX BLT W/S M8×25	
206	000-T00412-0C	M SCR TH CRM M4×12	
207	060-F00600-0B	FLT WSHR BLK M6	
208	000-P00420-W	M SCR PH W/FS M4×20	
209	050-F00400	FLG NUT M4	
210	000-P00312-W	M SCR PH W/FS M3×12	
211	050-H01600	HEX NUT M16	
212	011-F00310	TAP SCR PH 3×10	
213	011-T00312	TAP SCR TH 3×12	
214	000-P00412-W	M SCR PH W/FS M4×12	
301	600-6659-24	WIRE HARN FRONT CABI EXT1	
302	600-6659-25	WIRE HARN FRONT CABI EXT2	
303	600-6659-26	WIRE HARN FRONT CABI EXT3	
304	600-6659-27	WIRE HARN FRONT CABI EXT4	
305	600-6659-28	WIRE HARN FRONT CABI EXT5	
306	600-6659-29	WIRE HARN FRONT CABI EXT6	
307	600-6659-30	WIRE HARN FRONT CABI EXT7	
308	600-6659-48	WIRE HARN FRONT CABI EXT8	
309	600-6659-50	WIRE HARN FRONT SPEAKER	
310	600-6659-55	WIRE HARN BRATH FRONT CABI	

⑨ ASSY SERVICE LID (TTR-1020)

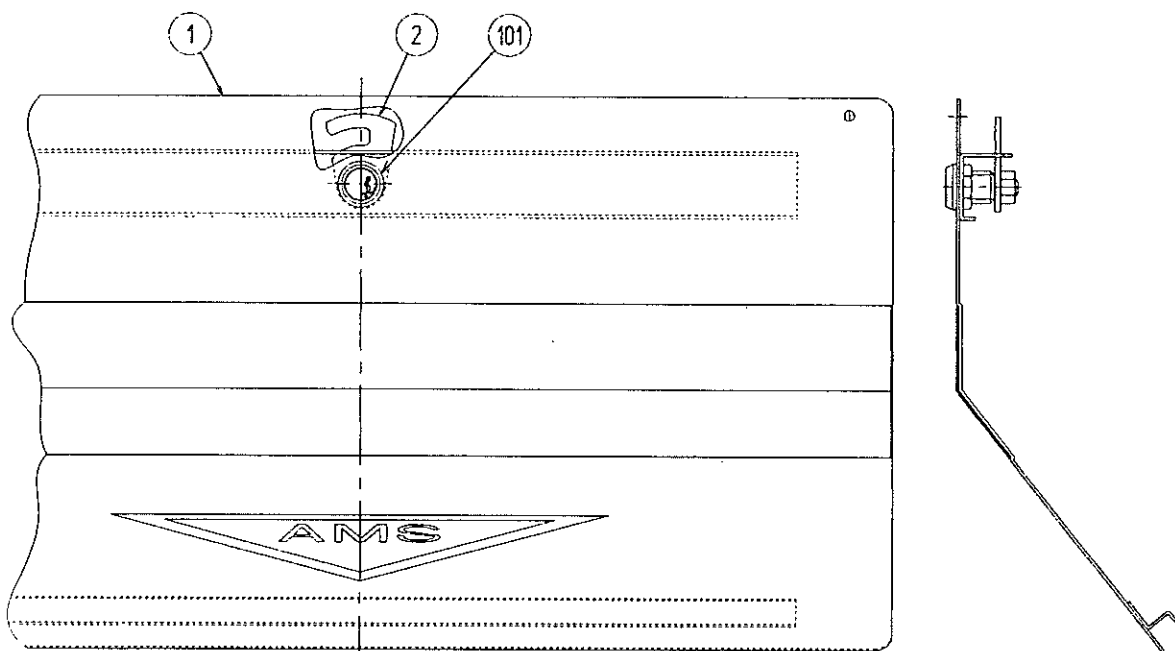

ITEM NO.	PART NO.	DESCRIPTION	NOTE
1	TTR-1021	SERVICE LID	
2	TH-1015	LOCKING TONGUE	
101	220-5380	MAG LOCK MASTER W/O KEY	

⑩ AC UNIT (TTR-1030)

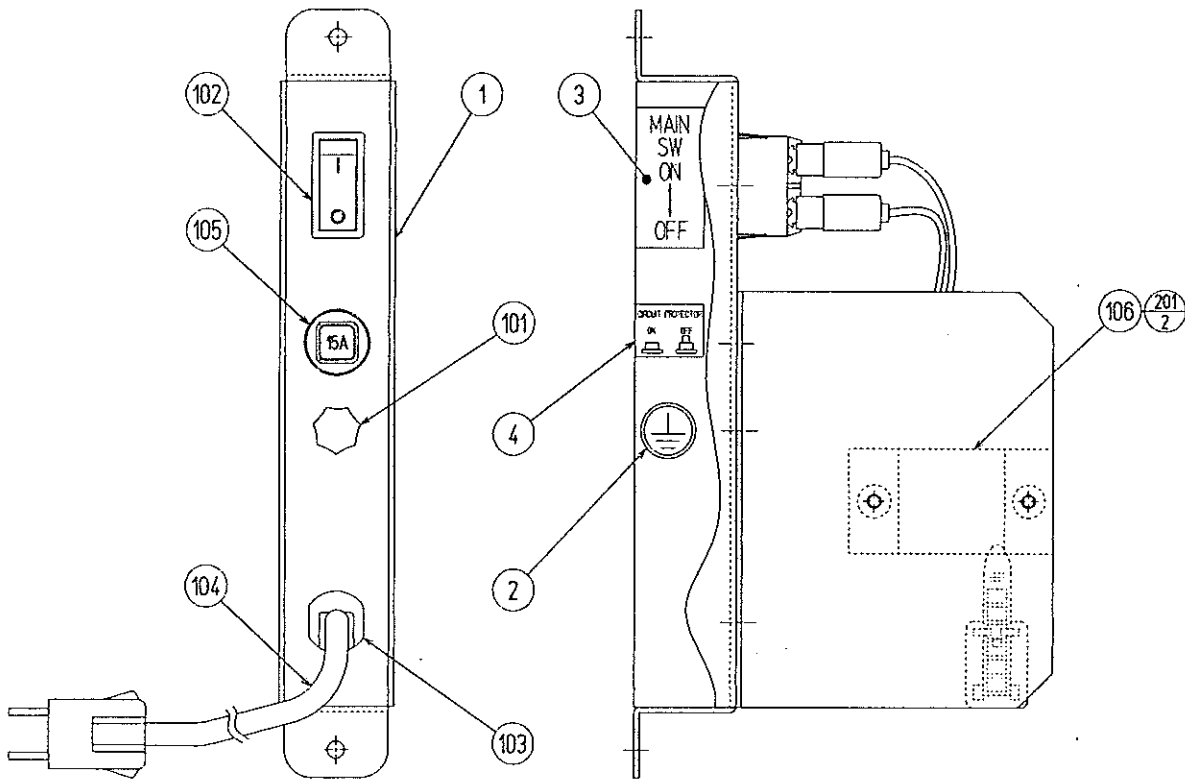

ITEM NO.	PART NO.	DESCRIPTION	NOTE
1	TTR-1031	AC BRKT	
2	421-8202	STICKER EARTH MARK	
3	421-6526	STICKER ON OFF	
4	421-7468-01	STICKER C. P. W/PIC	
101	280-0417	TERMINAL BINDING POST BLACK	
102	509-5453-V-B	SW ROCKER J8 V-B	
103	280-5134-6N34	BUSHING STRAIN RELIEF 6N34	TAIWAN
	280-5134-6N4	BUSHING STRAIN RELIEF 6N4	USA
104	600-5843-25	CA & PLUG ASSY 15A W/-F- L=2.5M	TAIWAN
	600-0110	CABLE & PLUG ASSY W/EARTH	USA
105	512-5033-15000	CIRCUIT PROTECTOR 15000mA	
106	117-5225	TERMINAL PLATE 3P 20A	
107	601-0460	PLASTIC TIE BELT 100MM	
108	280-5009	CORD CLAMP ϕ 21	
109	209-0032	CONN CLOSED END	
201	000-P00412-S	M SCR PH W/S M4 \times 12	
301	600-6659-01	WIRE HARN AC UNIT	
302	600-6659-54	WIRE HARN BARTH AC UNIT	
/	211-0167	TERM LUG RND ID5	USA

⑩ AC UNIT EXP (TTR-1040)

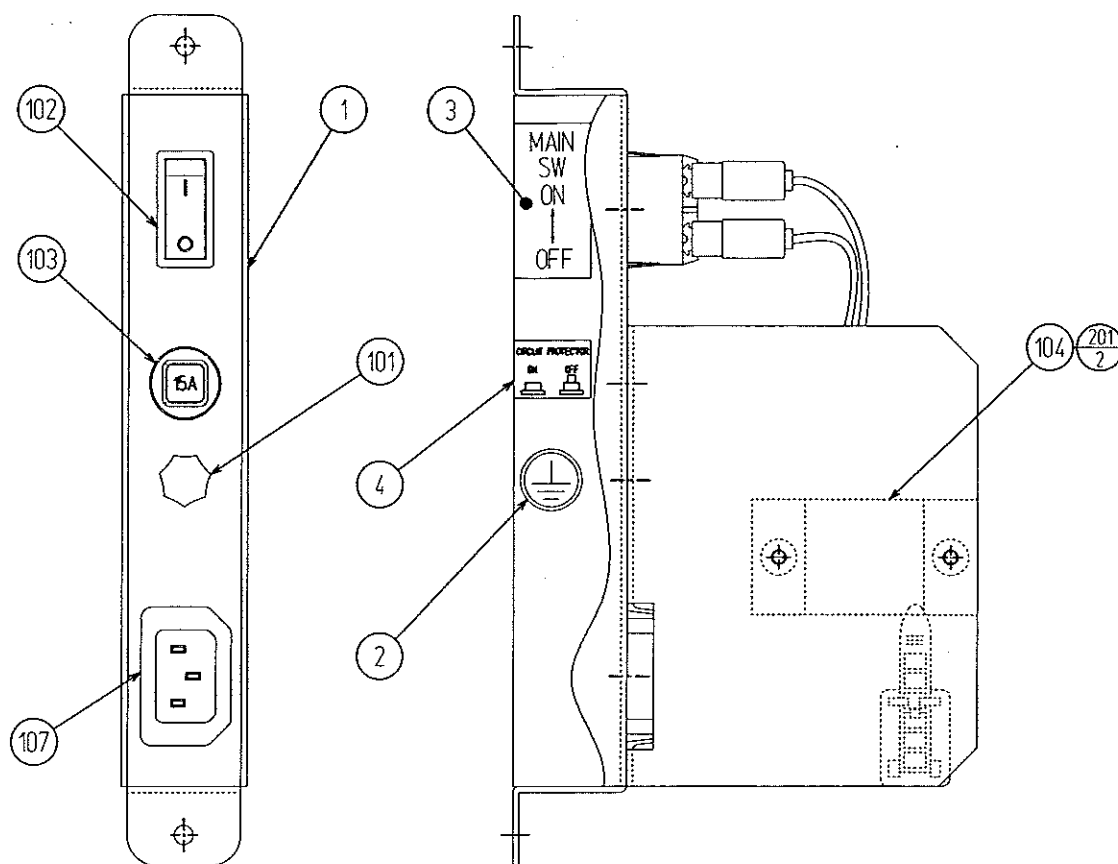

ITEM NO.	PART NO.	DESCRIPTION	NOTE
1	TTR-1041	AC BRKT EXP	
2	421-8202	STICKER EARTH MARK	
3	421-6526	STICKER ON OFF	
4	421-7468-01	STICKER C. P. W/PIC	
101	280-0417	TERM BINDING POST BLACK	
102	509-5453-V-B	SW ROCKER J8 V-B(MATSUSHITA)	
103	512-5033-8000	CIRCUIT PROTECTOR 8000mA	
104	117-5225	TERMINAL PLATE 3P 20A	
105	601-0460	PLASTIC TIE BELT 100mm	
106	280-5009	CORD CLAMP ϕ 21	
107	214-0202	AC INLET PANEL TYPE	
201	000-P00412-S	M SCR PH W/S M4 \times 12	
301	600-6659-62	WIRE HARN AC UNIT EXP	
302	600-6659-54	WIRE HARN EARTH AC UNIT	

⑪ ASSY SHIELD CASE (TTR-1100)

(D-1/2)

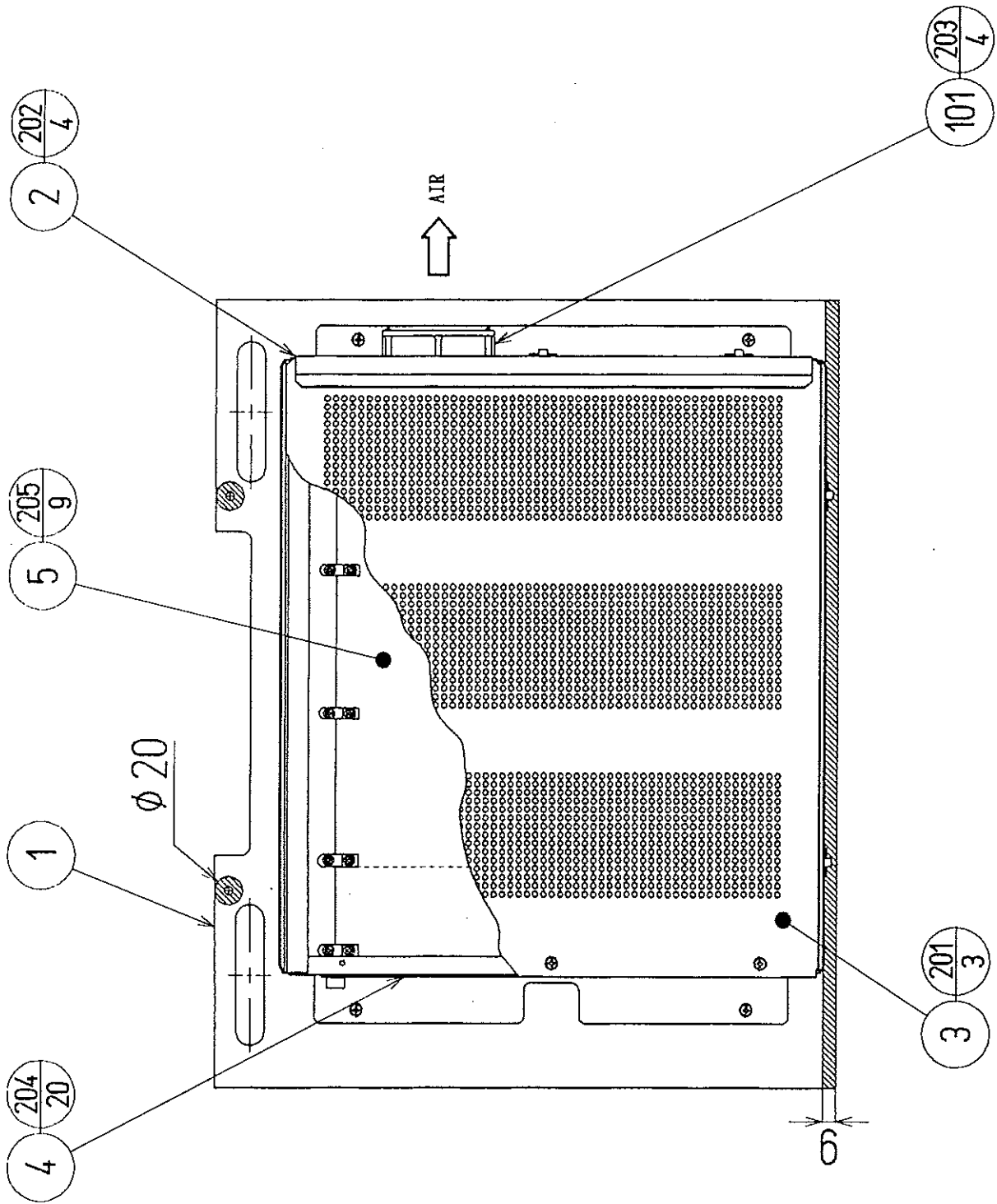

⑪ ASSY SHIELD CASE (TTR-1100)

(D-2/2)

ITEM NO.	PART NO.	DESCRIPTION	NOTE
1	TTR-1101	SHIELD CASE BASE	
2	105-5218	SHIELD- CASE	
3	105-5219-91	SHIELD CASE LID	
4	839-0744	FILTER BD A-CRX RALLY	
5	833-12276	GAME BD MANX T, T DX	
101	260-0055	FAN MOTOR DC5V	
102	209-0023	CONN CLOSED END	
103	280-5009	CORD CLAMP ϕ 21	
104	280-5275-SR10	CORD CLAMP SR10	
105	280-0419	HARNESS LUG	
106	601-0460	PLASTIC TIE BELT 100MM	
201	000-P00408-W	M SCR PH W/FS M4 \times 8	
202	000-P00412-W	M SCR PH W/FS M4 \times 12	
203	000-P00330-W	M SCR PH W/FS M3 \times 30	
204	010-P00308-F	S-TITE SCR PH W/F M3 \times 8	
205	010-P00310-F	S-TITE SCR PH W/F M3 \times 10	
206	011-F00310	TAP SCR FH 3 \times 10	
207	011-T00312	TAP SCR TH 3 \times 12	
208	011-T03512	TAP SCR TH 3.5 \times 12	
301	600-6659-20	WIRE HARN SHIELD CASE 1	
302	600-6659-21	WIRE HARN SHIELD CASE 2	
303	600-6659-22	WIRE HARN SHIELD CASE 3	
304	600-6659-23	WIRE HARN SHIELD CASE 4	
305	600-6445-38	WIRE HARN SHIELD CASE CRX MIDI	
306	600-6502-13	WIRE HARN DC FAN	

⑫ ASSY REAR BASE (TTR-3000)

(D-1/2)

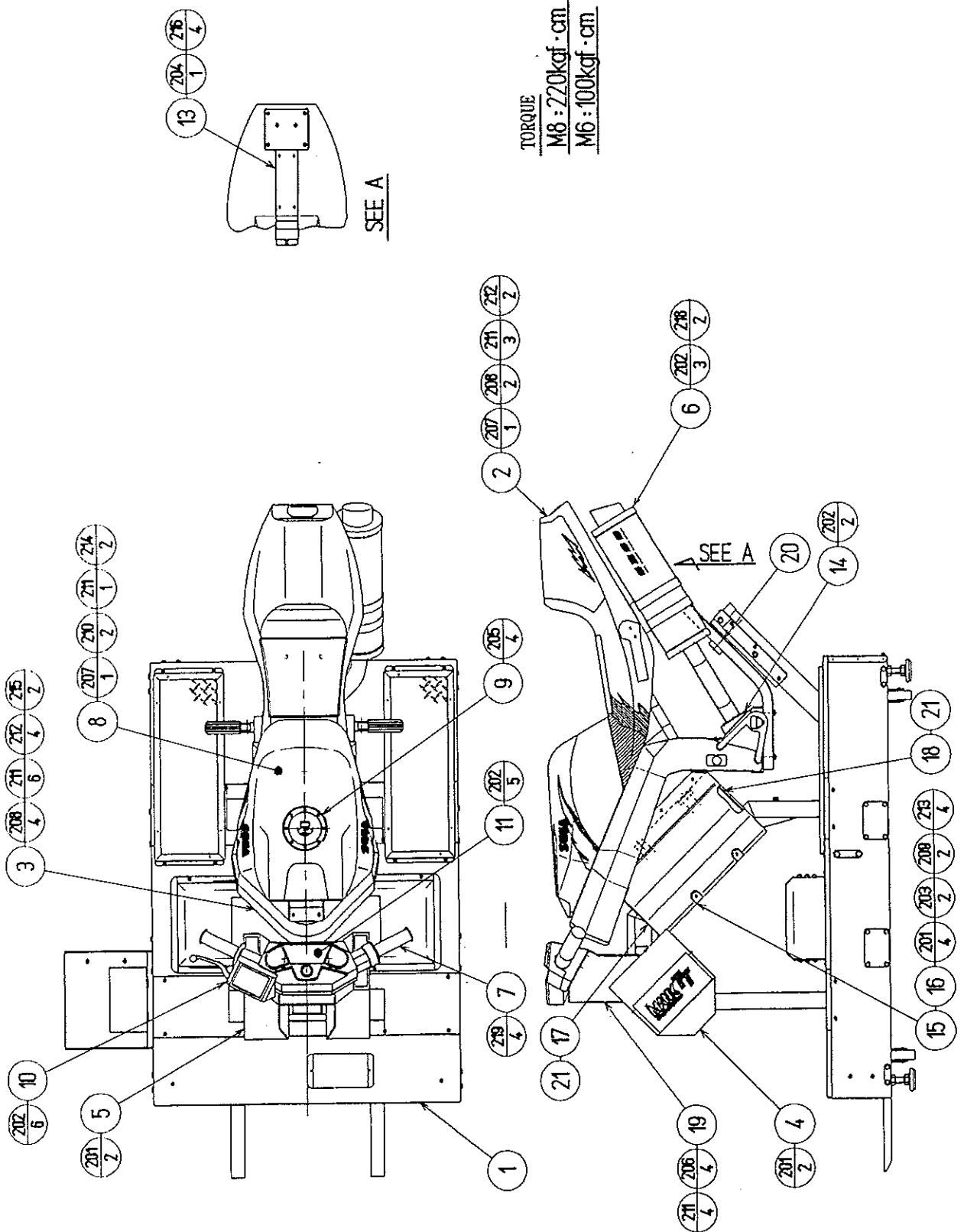

⑫ ASSY REAR BASE (TTR-3000)

(D-2/2)

ITEM NO.	PART NO.	DESCRIPTION	NOTE
1	TTR-3020	ASSY REAR CABI	
2	TTR-3050	ASSY SEAT COWL	
3	TTR-3070	ASSY BIKE FRAME	
4	TTR-3080	ASSY SPEAKER L	
5	TTR-3085	ASSY SPEAKER R	
6	TTR-3090	ASSY MUFFLER	
7	610-0391	ASSY HANDLE MECHA	
8	TTR-3001	TANK	
9	TTR-3002	FUEL CAP	
10	TTR-3003	BRAKE COVER	
11	TTR-3004	HANDLE COVER	
13	TTR-3007	WIRE COVER	
14	TTR-3008	FRAME LID	
15	TTR-3009	MECHA COVER L	
16	TTR-3010	MECHA COVER R	
17	TTR-3011	COVER PLATE F	
18	TTR-3012	COVER PLATE R	
19	TTR-3013	HANDLE BRKT	
20	TTR-3014	SAFETY COLLAR	
21	TTR-3015	GLUE PLATE	
201	000-T00408-0B	M SCR TH BLK M4×8	
202	000-T00408-0C	M SCR TH CRM M4×8	
203	000-T00416-0B	M SCR TH BLK M4×16	
204	000-P00412-WB	M SCR PH W/FS BLK M4×12	
205	020-000410-HZ	HEX SKT CAP SCR BLK OZ M4×10	
206	030-000820-SB	HEX BLT W/S BLK M8×20	
207	030-000830-SB	HEX BLT W/S BLK M8×30	
208	050-U00800	U NUT M8	
209	050-C00400-3B	CAP NUT TYPE3 BLK M4	
210	060-F00600-0B	FLT WSHR BLK M6	
211	060-F00800-0B	FLT WSHR BLK M8	
212	060-S00800-0B	SPR WSHR BLK M8	
213	068-441616-0B	FLT WSHR BLK 4.4-16×1.6	
214	020-000625-HZ	HEX SKT CAP SCR BLK OZ M6×25	
215	020-000830-HZ	HEX SKT CAP SCR BLK OZ M8×30	
216	FAS-110005	TAP SCR TH CRM M4×12	
218	000-T00512-0C	M SCR TH CRM M5×12	
219	FAS-300001	HEX BLT W/FS CRM M8×20	

⑬ HANDLE COVER (TTR-3004)

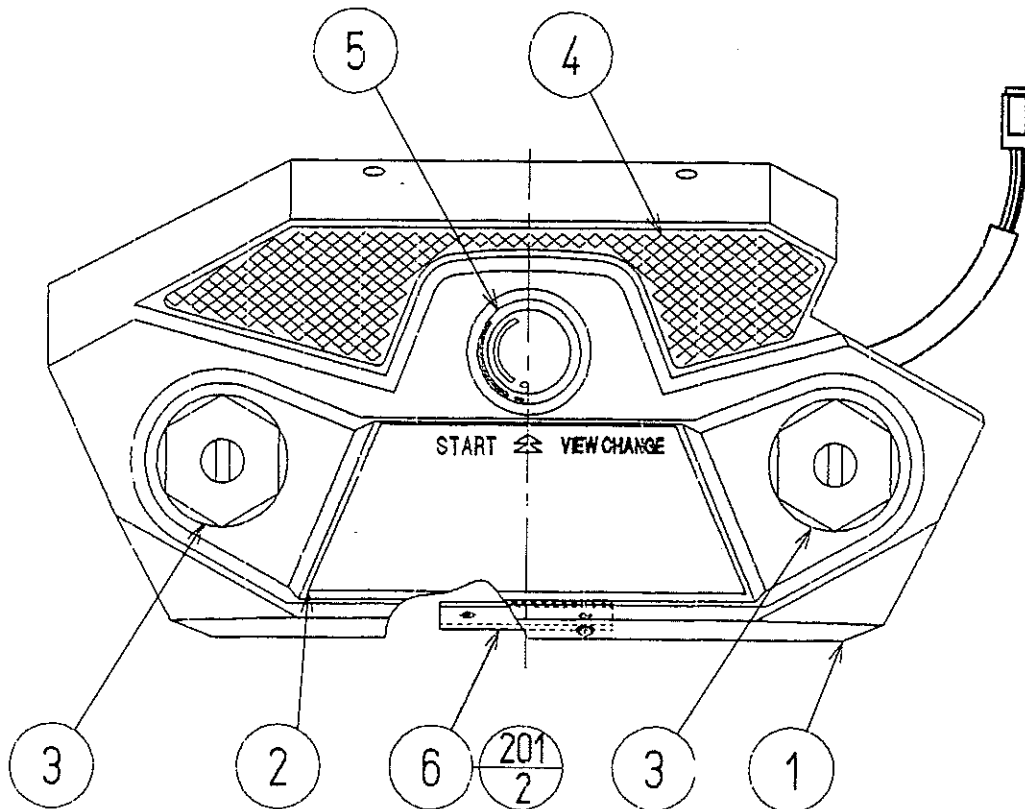

ITEM NO.	PART NO.	DESCRIPTION	NOTE
1	TTR-3004-A	HANDLE COVER BLANK	
2	TTR-3004-B	STICKER START	
3	TTR-3004-C	STICKER TOP BRIDGE	
4	TTR-3004-D	STICKER CARBON	
5	509-0161	PUSH BUTTON SWITCH 1T YELLOW W/LAMP	
6	TTR-3005	COVER HOLDER HOOK	
201	047-PA3207-6	RVT OPEN TYPE AL 3.2×7.6	
301	600-6659-46	WIRE HARN HANDLE UNIT 2	

⑭ ASSY REAR CABI (TTR-3020)

(D-1/2)

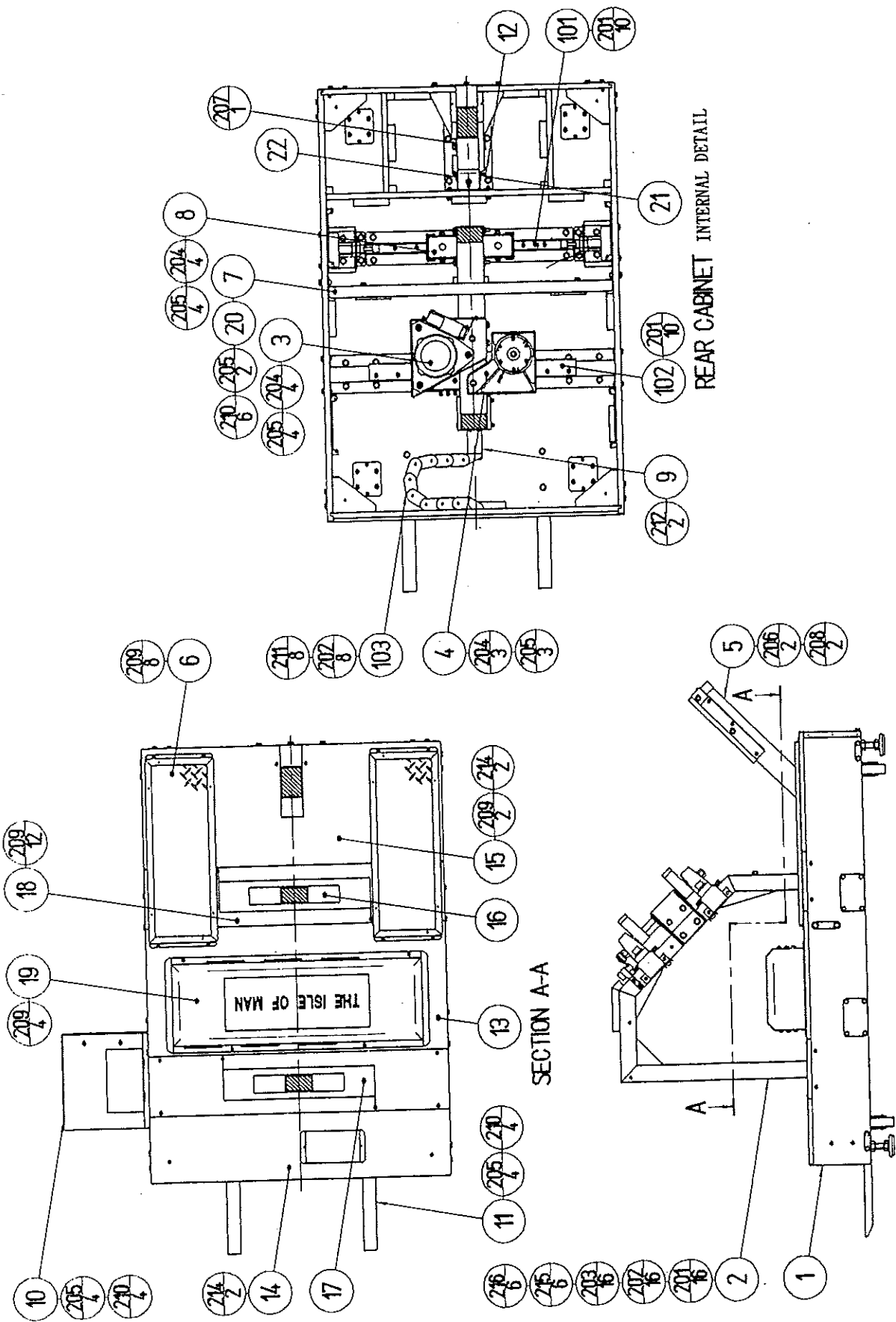

①4 ASSY REAR CABI (TTR-3020)

(D-2/2)

ITEM NO.	PART NO.	DESCRIPTION	NOTE
1	TTR-3100	ASSY SUB REAR CABI	
2	TTR-3200	ASSY SLIDE FRAME	
3	TTR-3300	ASSY SLIDE MOTOR	
4	TTR-3400	ASSY BRAKE	
5	TTR-3500	ASSY REAR GUIDE	
6	TTR-3600	ASSY STEP	
7	TTR-3021	CABINET BRIDGE	
8	TTR-3022	SLIDBR CAP	
9	TTR-3023	CABLE BEAR BRKT	
10	TTR-3024	TOWER BASE	
11	TTR-3025	JOINT BRKT	
12	TTR-3026	PILLAR SHAFT	
13	TTR-3027	BASE LID C	
14	TTR-3028	BASE LID F	
15	TTR-3029	BASE LID R	
16	TTR-3030	SLIDE PLATE S	
17	TTR-3031	SLIDE PLATE L	
18	TTR-3032	PLATE COVER	
19	TTR-3033	MAINTENANCE LID	
20	TTR-3034	PLATE 9-60	
21	TTR-3035	FLT 12.5-45×2.6	
22	TTR-3036	FLT 8.5-45×2.6	
101	100-5225	SLIDE RAIL SR25	SEE 102
102	100-5226	SLIDE RAIL GSR25	SEE 101
103	601-7757-009	CABLE BEAR TKP0450-1B R=50 L=9	
104	280-5009	CORD CLAMP φ21	
201	FAS-200004	HEX SKT H CAP SCR BLK OZ M6×14	
202	060-F00600	FLT WSHR M6	
203	060-S00600	SPR WSHR M6	
204	030-000820-S	HEX BLT W/S M8×20	
205	060-F00800	FLT WSHR M8	
206	050-U00800	U NUT M8	
207	068-852216	FLT WSHR 8.5-22×1.6	
208	060-S00800	SPR WSHR M8	
209	000-T00408-0B	M SCR TH BLK M4×8	
210	030-000830-SB	HEX BLT W/S BLK M8×30	
211	030-000620-S	HEX BLT W/S M6×20	
212	000-P00408-W	M SCR PH W/FS M4×8	
213	011-F00310	TAP SCR FH 3x10	
214	000-T00420-0B	M SCR TH BLK M4×20	
215	000-T00530-0B	M SCR TH BLK M5×30	
216	050-H00500	HEX NUT M5	
217	050-F00400	FLG NUT M4	
301	600-6659-33	WIRE HARN BASE1	
302	600-6659-34	WIRE HARN BASE2	
303	600-6659-35	WIRE HARN BASE3	
304	600-6659-36	WIRE HARN BASE4	
305	600-6659-37	WIRE HARN BASE5	
306	600-6659-56	WIRE HARN EARTH REAR CABI	

76
 BEARING CARRIAGE
 ASSY
 SR25WSS6
 GSR25TSS

⑮ ASSY SEAT COWL (TTR-3050)

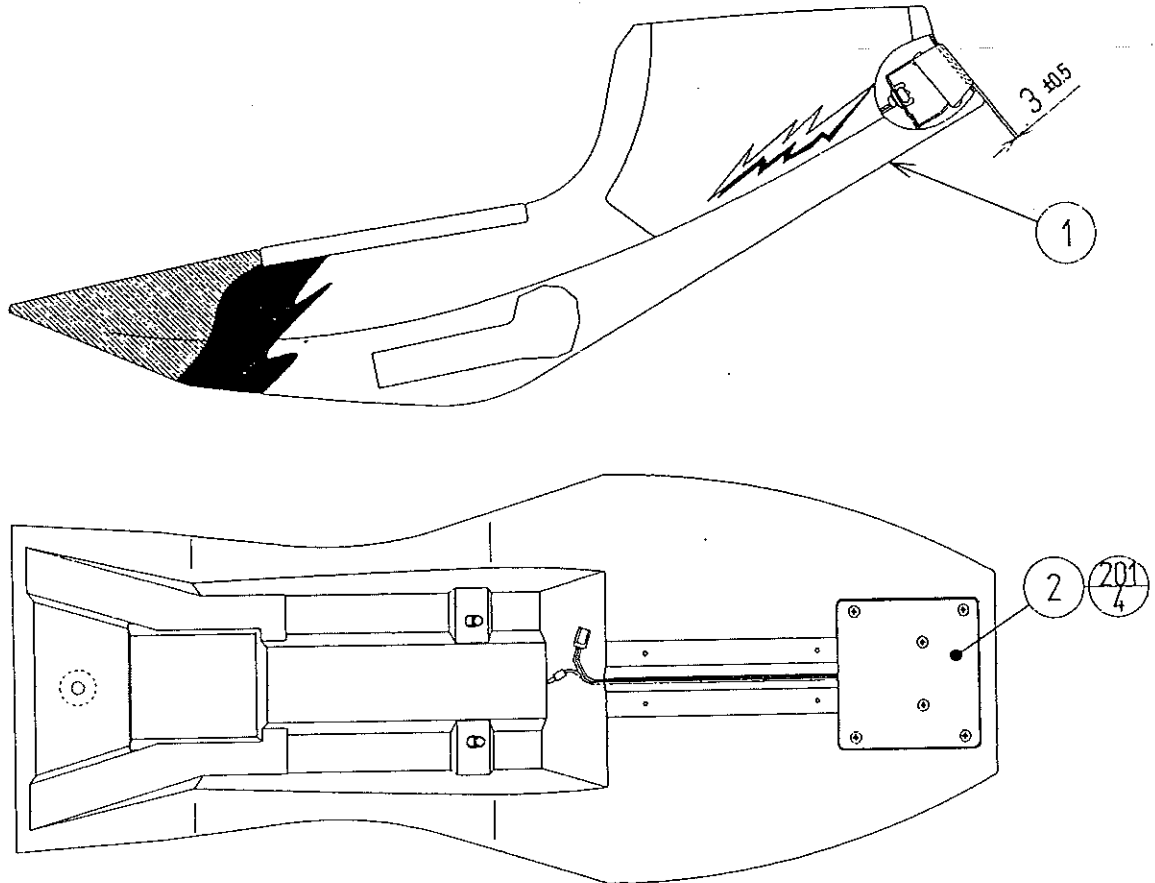

ITEM NO.	PART NO.	DESCRIPTION	NOTE
1	TTR-3051	SEAT COWL	
2	TTR-3060	ASSY TAIL LIGHT	
201	FAS-110005	TAP SCR TH CRM M4×12	

①⑥ ASSY TAIL LIGHT (TTR-3060)

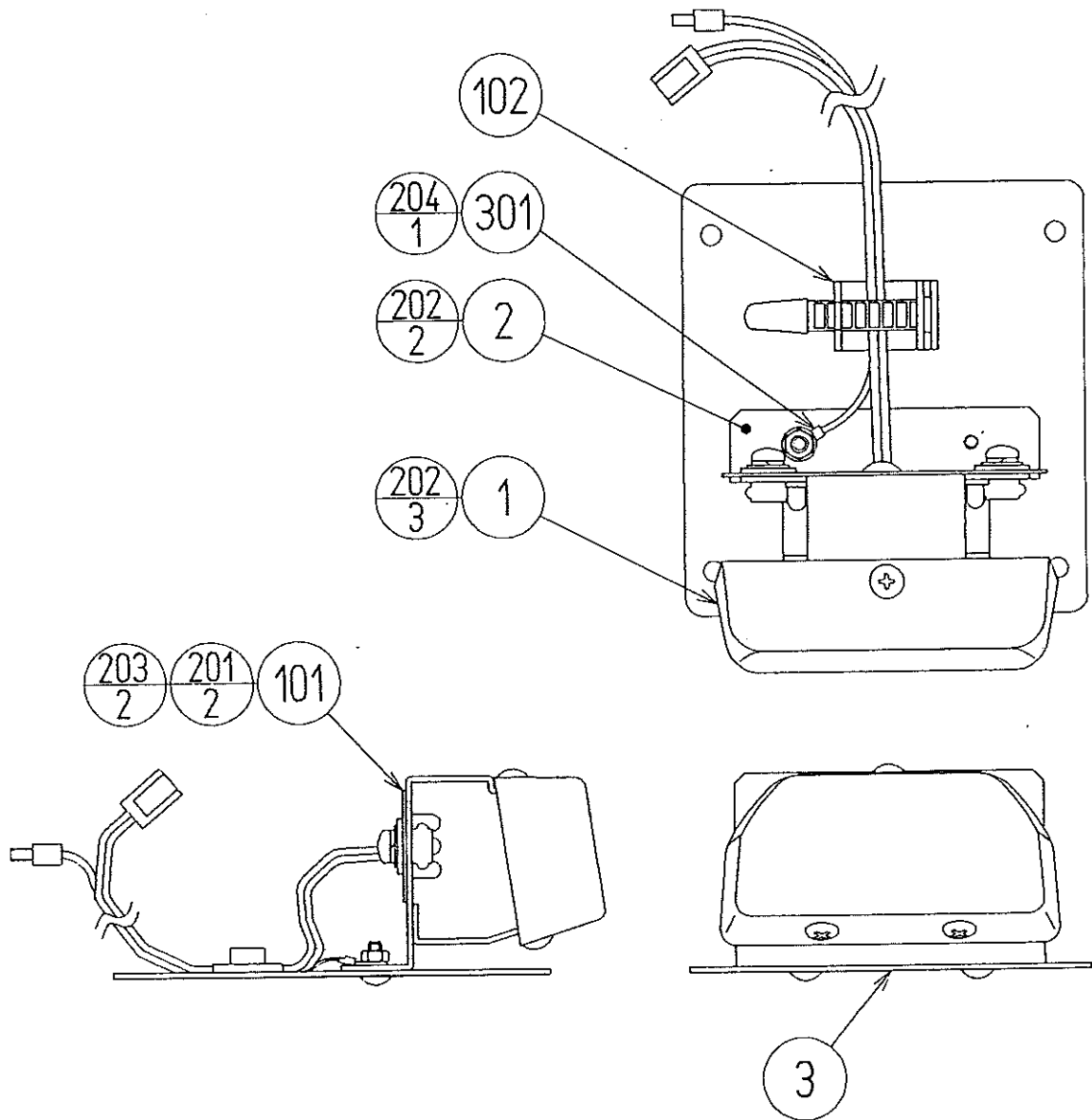

ITEM NO.	PART NO.	DESCRIPTION	NOTE
1	TTR-3061	LENS	
2	TTR-3062	LED BRKT	
3	TTR-3063	TAIL LID	
101	390-5621	LED BD	
102	280-5008	CORD CLAMP $\phi 15$	
201	000-P00520-W	M SCR PH W/FS M5 \times 20	
202	000-T00408-OC	M SCR TH CRM M4 \times 8	
203	FAS-500010	KURATITE NUT M5	
204	050-F00400	FLG NUT M4	
301	600-6659-61	WIRE HARN EARTH TAIL LIGHT	

⑰ ASSY BIKE FRAME (TTR-3070)

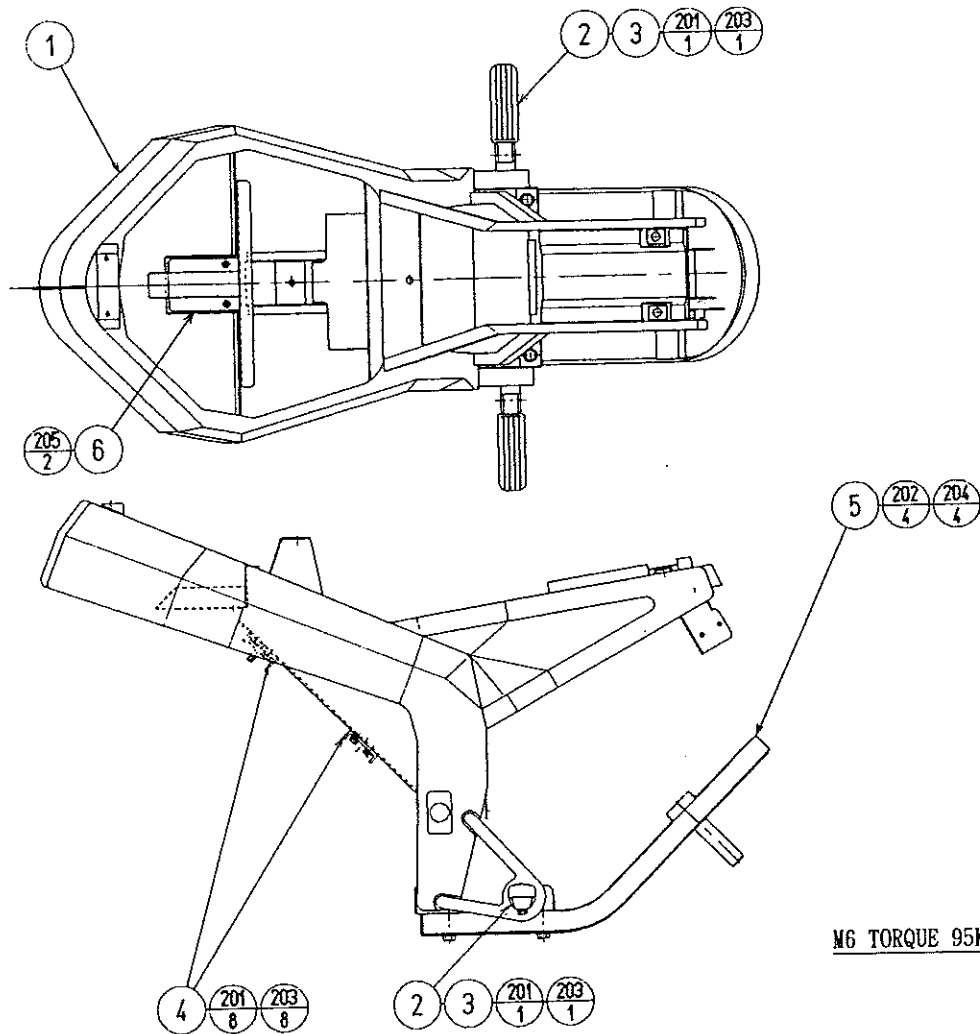

M6 TORQUE 95Kgf•cm

ITEM NO.	PART NO.	DESCRIPTION	NOTE
1	TTR-3071	BIKE FRAME	
2	TTR-3072	STEP RUBBER	
3	TTR-3073	STEP COLLAR	
4	TTR-3074	SUB MOUNT PLATE	
5	TTR-3075	REAR FRAME	
6	TTR-3076	INNER COVER	
101	280-5009	CORD CLAMP ϕ 21	
201	030-000620-SB	HEX BLT BLK W/S M6 \times 20	
202	030-000840-SB	HEX BLT BLK W/S M8 \times 40	
203	060-F00600	PLT WSHR M6	
204	060-F00800	PLT WSHR M8	
205	010-P00408-F	S-TITE SCR PH W/F M4 \times 8	
301	600-6659-41	WIRE HARN BIKE FRAME1	
302	600-6659-57	WIRE HARN EARTH BIKE FRAME	

⑱ ASSY SPEAKER L (TTR-3080)

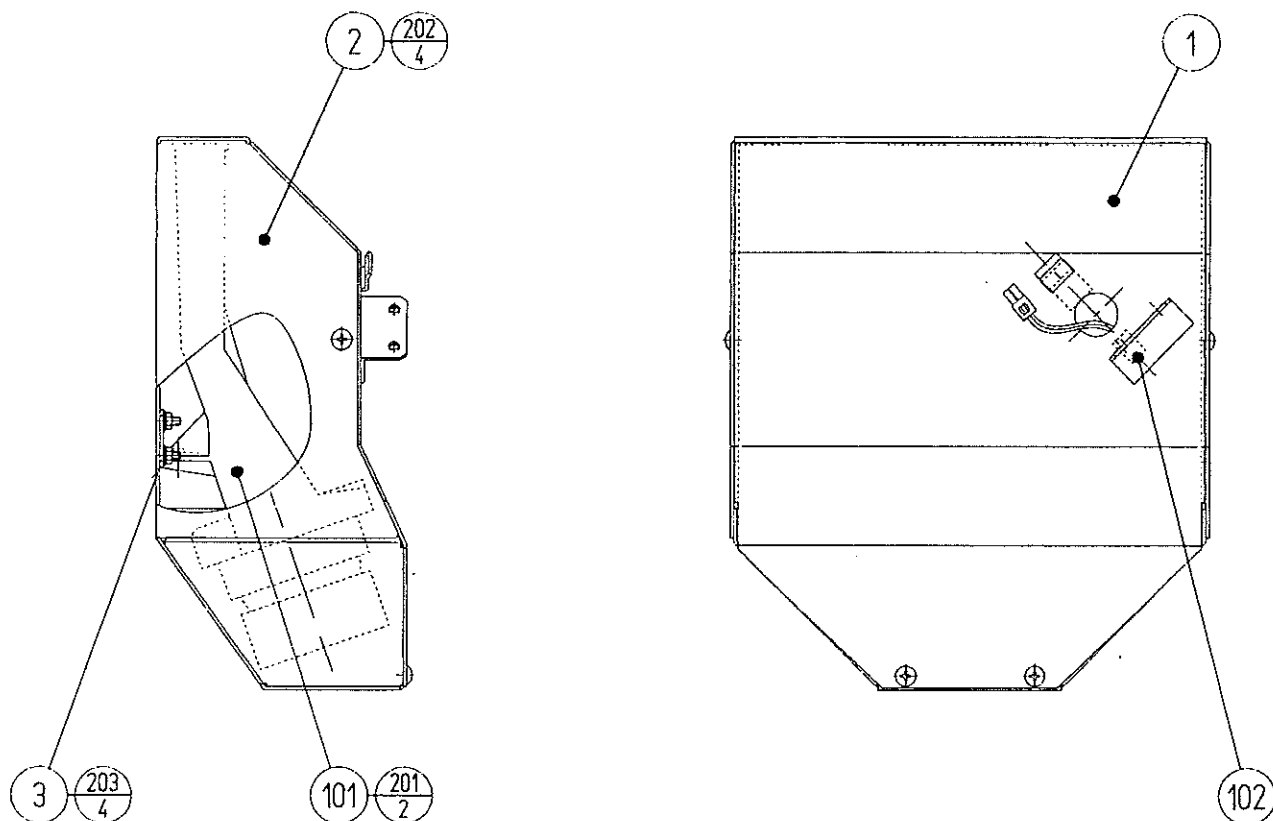

ITEM NO.	PART NO.	DESCRIPTION	NOTE
1	TTR-3081	BASE PLATE L	
2	TTR-3082	SPEAKER COVER	
3	TTR-3083	SPEAKER HOLDER	
101	130-5140	SPEAKER BOX MINI DOME	
102	280-5008	CORD CLAMP ϕ 15	
201	000-P00412-W	M SCR PH W/FS M4 \times 12	
202	000-T00408-0B	M SCR TH BLK M4 \times 8	
203	050-F00400	FLG NUT M4	
301	600-6659-51	WIRE HARN SPEAKER MID	

①9 ASSY SPEAKER R (TTR-3085)

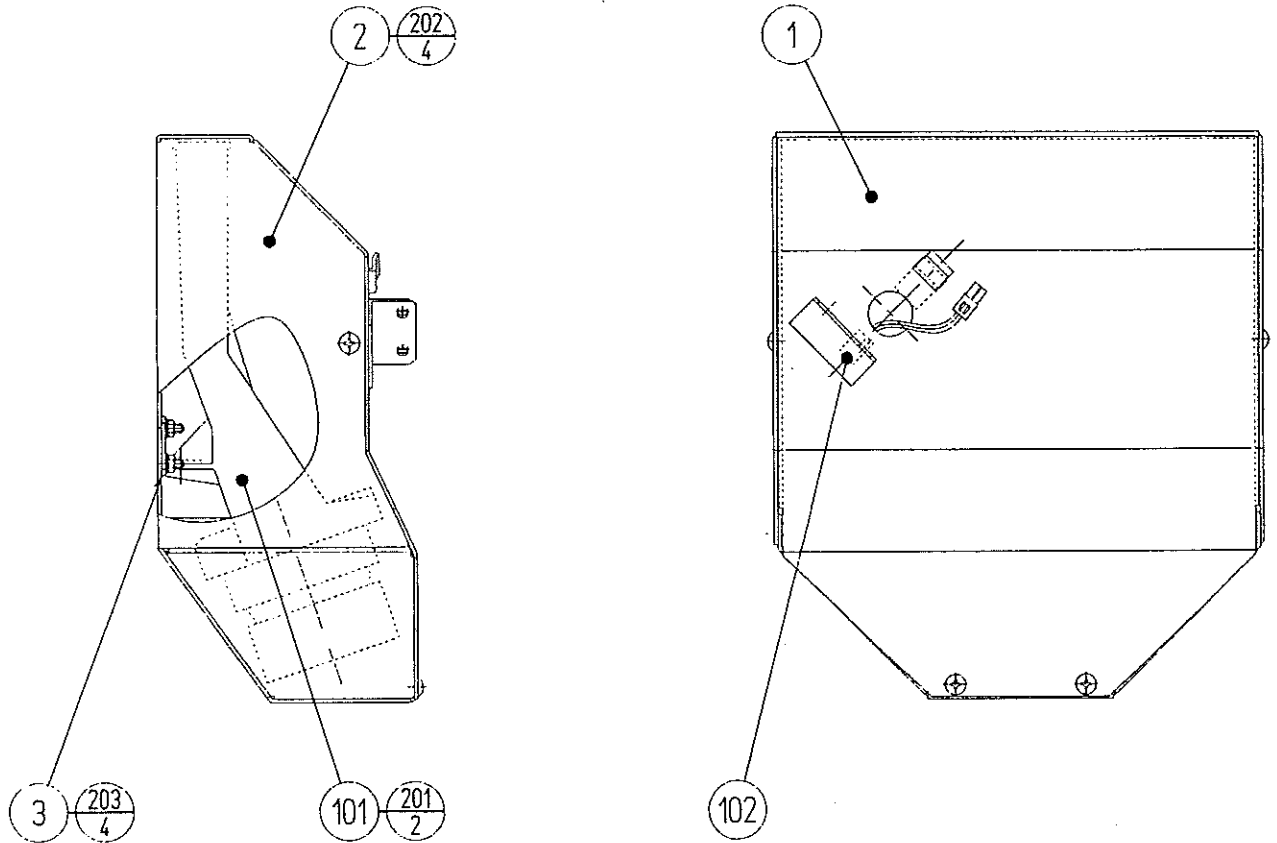

ITEM NO.	PART NO.	DESCRIPTION	NOTE
1	TTR-3086	BASE PLATE R	
2	TTR-3082	SPEAKER COVER	
3	TTR-3083	SPEAKER HOLDER	
101	130-5140	SPEAKER BOX MINI DOME	
102	280-5008	CORD CLAMP ϕ 15	
201	000-P00412-W	M SCR PH W/FS M4 \times 12	
202	000-T00408-0B	M SCR TH BLK M4 \times 8	
203	050-F00400	FLG NUT M4	
301	600-6659-51	WIRE HARN SPEAKER MID	

②⑩ ASSY MUFFLER (TTR-3090)

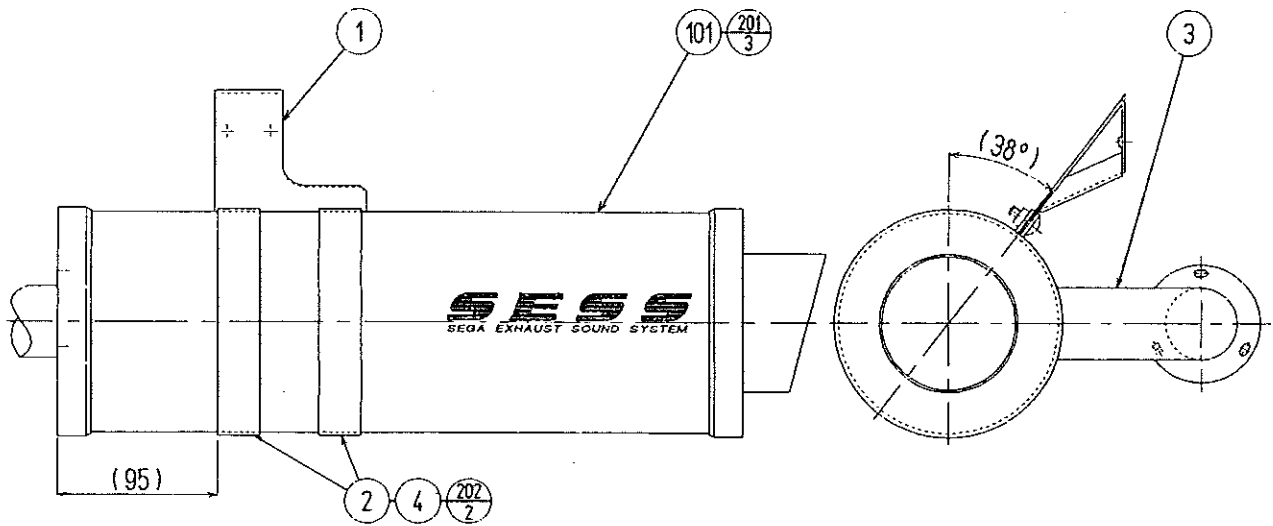

ITEM NO.	PART NO.	DESCRIPTION	NOTE
1	TTR-3091	MOUNT BRKT	
2	TTR-3092	SILENSOR BAND	
3	TTR-3093	CENTER PIPE	
4	TTR-3094	CUSHION RUBBER	
101	130-5147	SPEAKER DUCT WOOFER	
201	FAS-110005	TAP SCR TH CRM M4×12	
202	000-T00616-0C	M SCR TH CRM M6×16	

②1 ASSY SUB REAR CABI (TTR-3100)

(D-1/2)

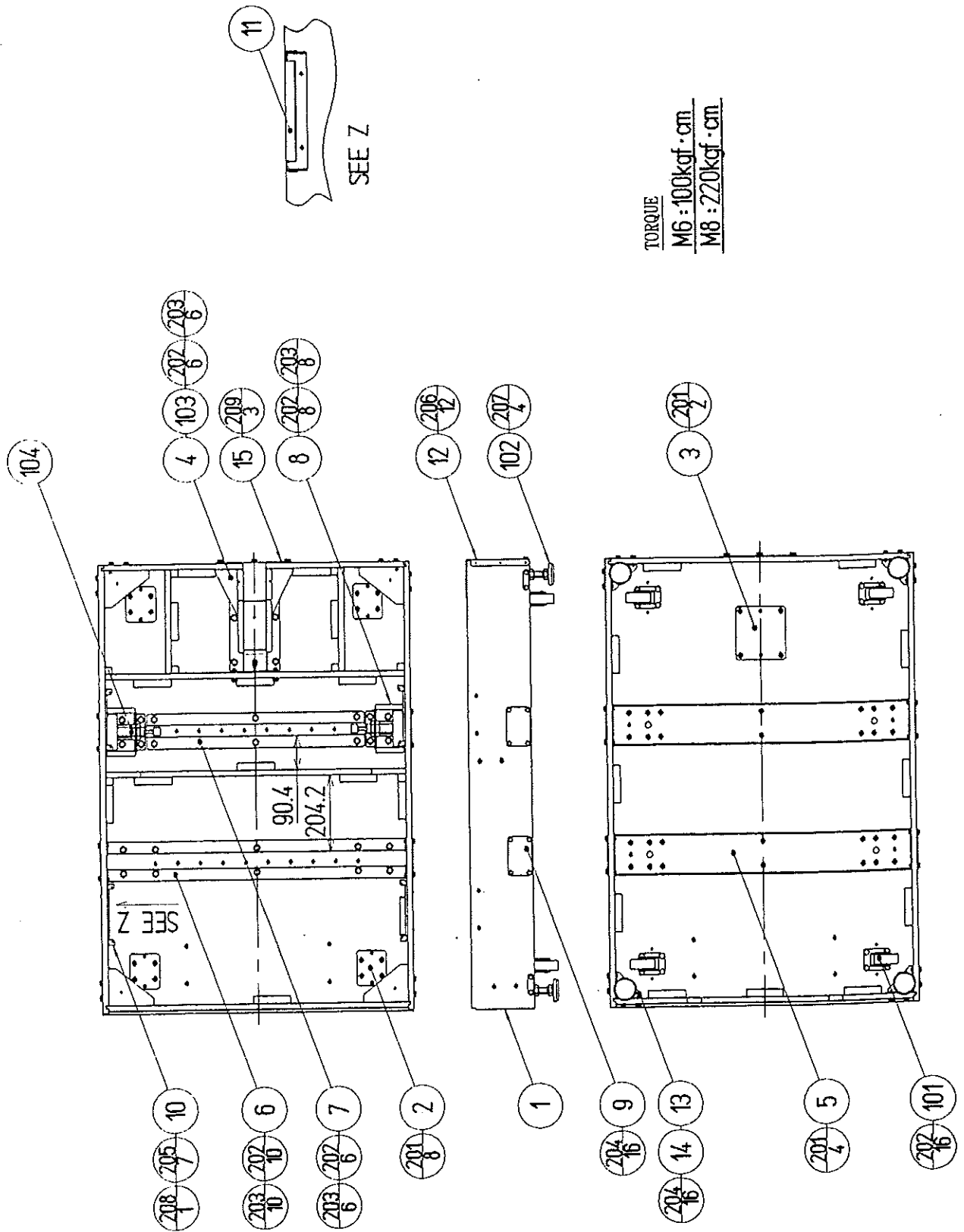

②1 ASSY SUB REAR CABI (TTR-3100)

(D-2/2)

ITEM NO.	PART NO.	DESCRIPTION	NOTE
1	TTR-3101	WOODEN REAR CABINET	
2	TTR-3102	NUT PLATE M8 S	
3	TTR-3103	NUT PLATE M8 L	
4	TTR-3104X	PILLAR BRKT	
5	TTR-3105	CABINET FRAME	
6	TTR-3106	RAIL BRKT F	
7	TTR-3107	RAIL BRKT R	
8	TTR-3108	BUFFER BRKT	
9	TTR-3109	SIDE PLATE	
10	TTR-3110	LID BRKT	
11	TTR-3111	PLATE PAD	
12	TTR-3112	EDGE PROTECTOR	
13	TTR-1010	LEG BRKT	
14	117-5233	PLATE LEG BRACKET BLACK	
15	TTR-3113	PLATE 9-90	
101	601-5471	CASTER	
102	601-5882	LEG ADJUSTER ϕ 60	
103	601-8541	STOPPER RI-30	
104	601-8517	SHOCK ABSORBER	
201	000-P00420-W	M SCR PH W/FS M4 \times 20	
202	030-000830-S	HEX BLT W/S M8 \times 30	
203	060-F00800	FLT WSHR M8	
204	030-000625-SB	HEX BLT W/S BLK M6 \times 25	
205	000-T00420-OB	M SCR TH BLK M4 \times 20	
206	079-000008	SCR NAIL THH STNLS 1.5 \times 16	
207	050-H01600-OB	HEX NUT BLK M16	
208	000-T00425-OB	M SCR TH BLK M4 \times 25	
209	030-000830-SB	HEX BLT W/S BLK M8 \times 30	

22 ASSY SLIDE FRAME (TTR-3200)

(D-1/2)

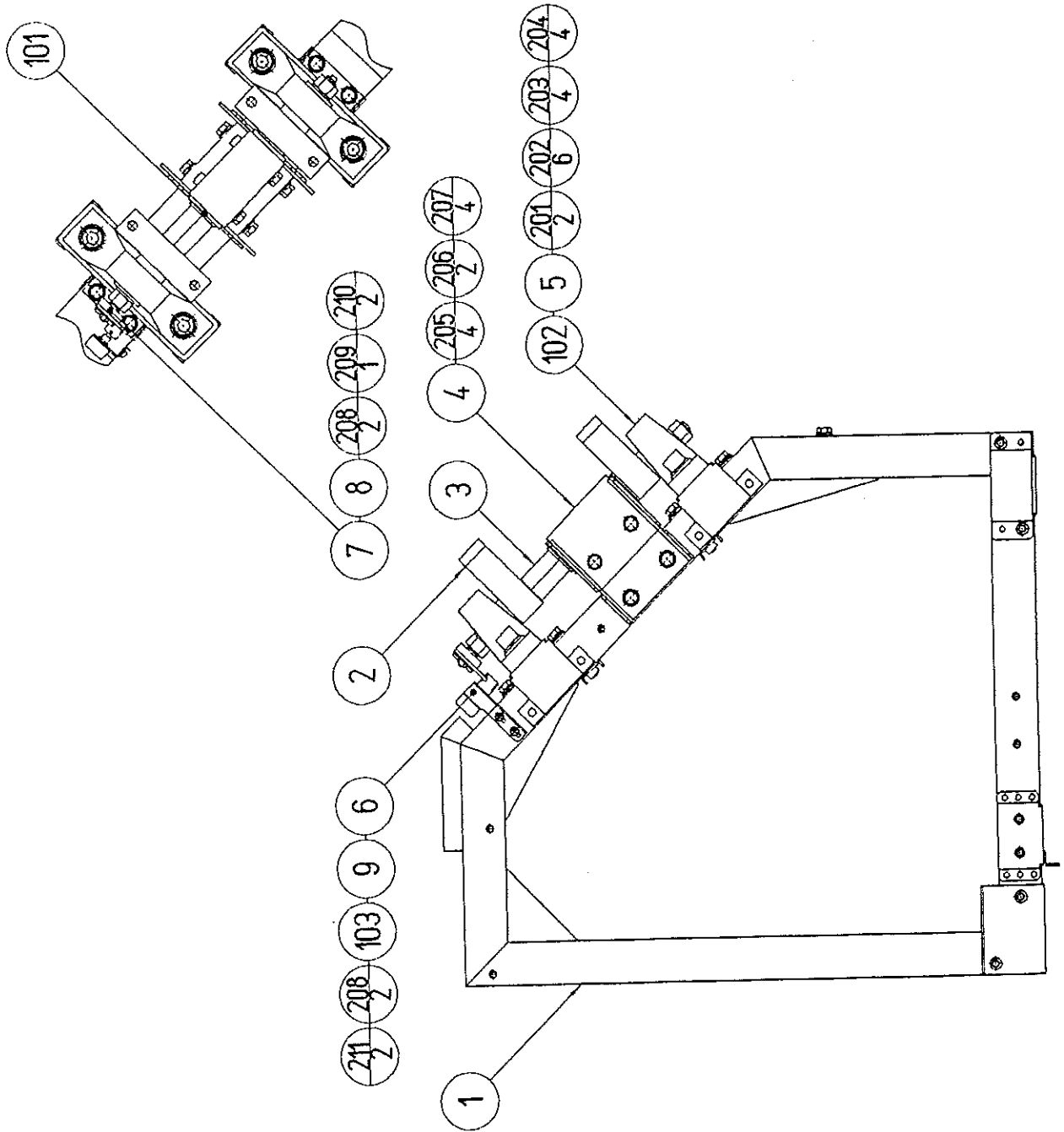

② ASSY SLIDE FRAME (TTR-3200)

(D-2/2)

ITEM NO.	PART NO.	DESCRIPTION	NOTE
1	TTR-3201	SLIDE FRAME	
2	TTR-3202	MOUNT BLOCK	
3	TTR-3203	CENTERING SHAFT	
4	TTR-3204	ROSTA BRKT	
5	TTR-3205	FLT 14, 5-36×3, 2	
6	TTR-3206	CENTERING VOL BRKT	
7	TTR-2009	GEAR HOLDER 80	
8	601-6005	ADJUST GEAR	
9	601-7945	GEAR 20	
101	601-8458	ROSTA □22	
102	100-5224	BEARING φ 25	
103	220-5484	VOL CONT B-5K OHM	
104	280-5009	CORD CLAMP φ 21	
105	280-5008	CORD CLAMP φ 15	
106	310-5029-F20	SUMITUBE F F20MM	
107	601-0460	PLASTIC TIE BELT 100MM	
108	601-6563-125	BUSH 2, 4t	
201	050-H01400	HEX NUT M14	
202	060-S01400	SPR WSHR M14	
203	FAS-200005	HEX SKT H CAP SCR BLK OZ M14×40	
204	060-F01400	FLT WSHR M14	
205	030-000820-S	HEX BLT W/S M8×20	
206	030-000860-S	HEX BLT W/S M8×60	
207	060-F00800	FLT WSHR M8	
208	000-P00408-W	M SCR PH W/FS M4×8	
209	050-U00500	U NUT M5	
210	028-C00416-P	SET SCR CH P M4×16	
211	028-C00308-P	SET SCR CH P M3×8	
302	600-6659-40	WIRE HARN SLIDE FRAME2	
303	600-6659-43	WIRE HARN ANGLE VOL	
304	600-6659-58	WIRE HARN EARTH SLIDE FRAME	

23 ASSY SLIDE MOTOR (TTR-3300)

(D-1/2)

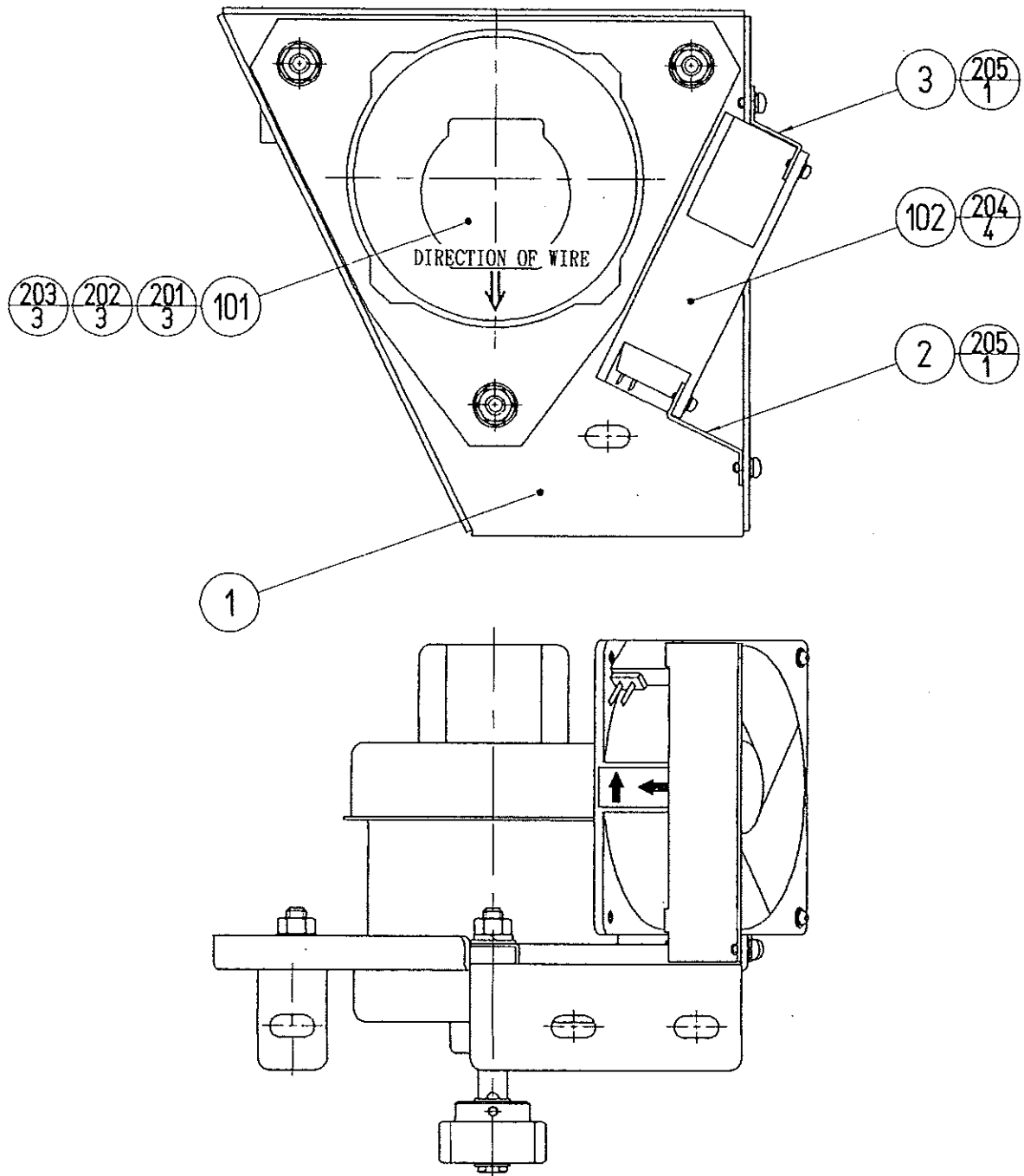

②③ ASSY SLIDE MOTOR (TTR-3300)

(D-2/2)

ITEM NO.	PART NO.	DESCRIPTION	NOTE
1	TTR-3301	MOTOR BRKT	
2	TTR-3302	FAN BRKT L	
3	TTR-3303	FAN BRKT R	
101	350-5401	SERVO MOTOR 500W	
102	260-0011-02	AXIAL FLOW FAN AC100V 50-60Hz	
103	280-5009	CORD CLAMP ϕ 21	
104	601-0460	PLASTIC TIE BBLT 100MM	
201	050-U00800	U NUT M8	
202	060-F00800	FLT WSHR M8	
203	060-S00800	SPR WSHR M8	
204	000-P00308-W	M SCR PH W/FS M3 \times 8	
205	000-P00408-W	M SCR PH W/FS M4 \times 8	
206	065-S012S0-Z	STP RING BLK OZ S12	
207	028-A00406-P	SET SCR HEX SKT CUP P M4 \times 6	
301	600-6659-47	WIRE HARN FAN MOTOR	

②④ ASSY BRAKE (TTR-3400)

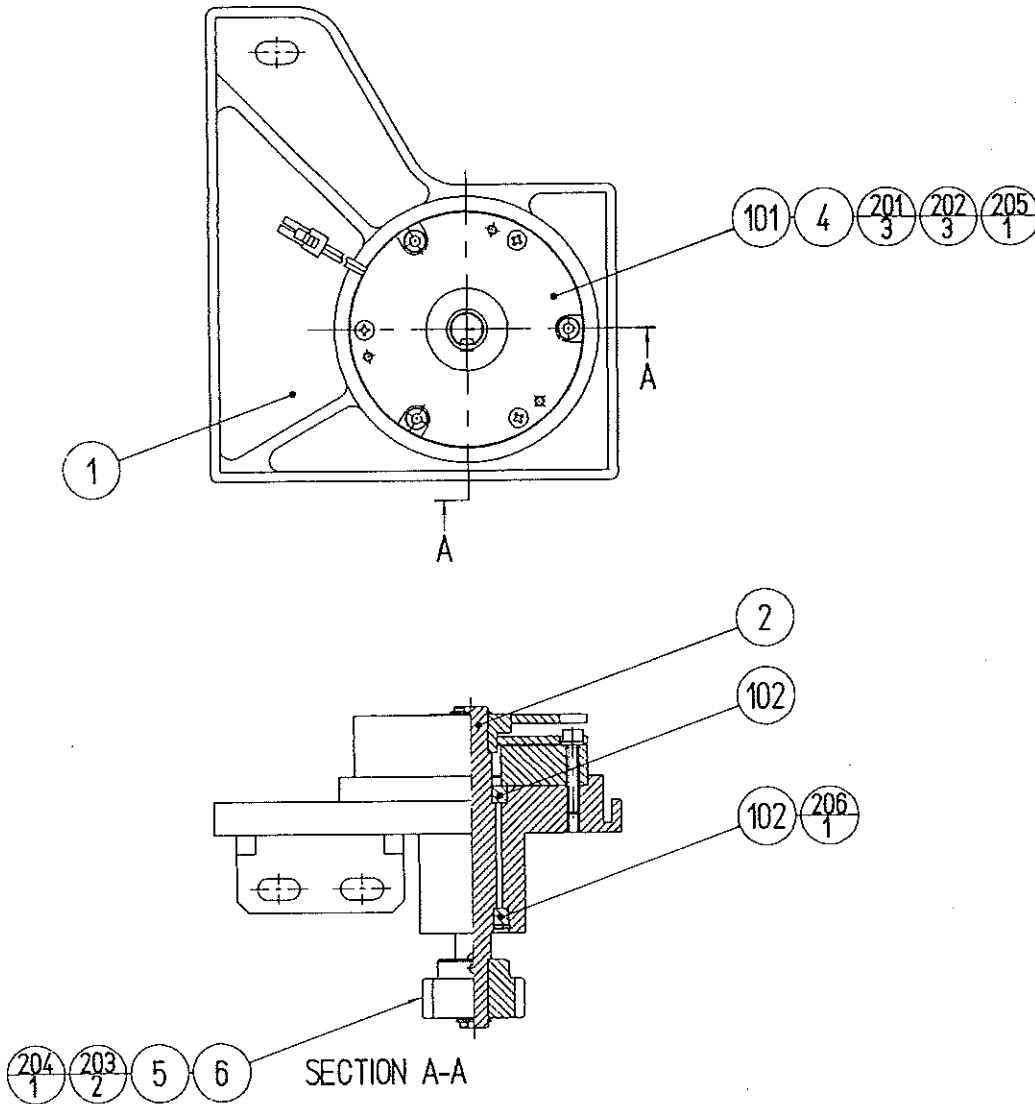

ITEM NO.	PART NO.	DESCRIPTION	NOTE
1	TTR-3401	BRAKE BASE	
2	TTR-3402	BRAKE SHAFT	
4	TTR-3404	KEY 5×5-12	
5	TTR-3304	KEY 5×5-24.5	
6	601-8459	PINION GEAR 20	
101	601-8518	BRAKE RNBO. 8G	
102	100-5229	BEARING φ17	
201	020-000525-OZ	HEX SKT H CAP SCR BLK OZ M5×25	
202	060-S00500	SPR WSHR M5	
203	028-A00406-P	SET SCR HEX SKT CUP P M4×6	
204	065-S012S0-Z	STP RING BLK OZ S12	
205	065-S014S0-Z	STP RING BLK OZ S14	
206	065-A030H0-Z	STP RING BLK OZ H30	

25 ASSY REAR GUIDE (TTR-3500)

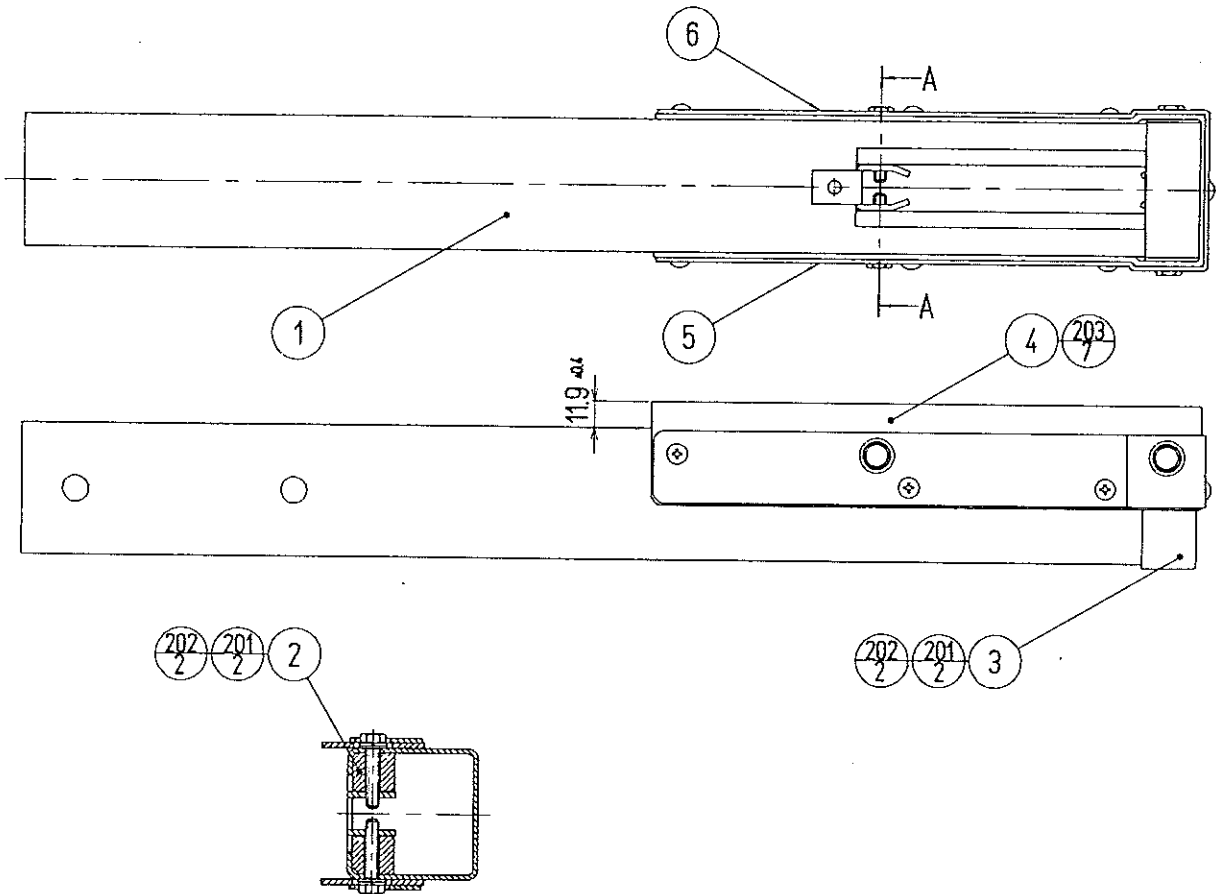

SECTION A-A

ITEM NO.	PART NO.	DESCRIPTION	NOTE
1	TTR-3501	GUIDE PILLAR	
2	TTR-3502	GUIDE BAR	
3	TTR-3503	PILLAR CAP	
4	TTR-3504	SAFETY RUBBER	
5	TTR-3505	RUBBER HOLDER L	
6	TTR-3506	RUBBER HOLDER R	
201	030-000630-SB	HEX BLT W/S BLK M6×30	
202	060-F00600-0B	FLT WSHR BLK M6	
203	000-T00408-0B	M SCR TH BLK M4×8	

②⑥ ASSY STEP (TTR-3600)

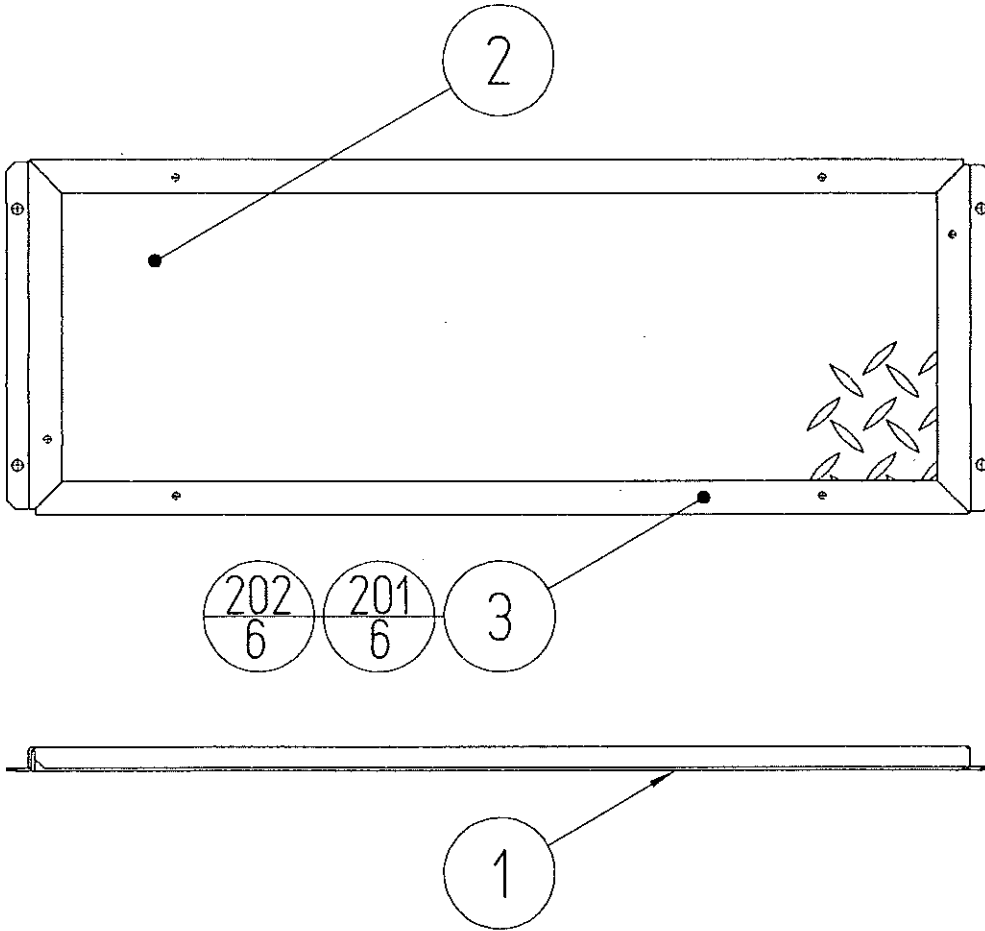

ITBM NO.	PART NO.	DESCRIPTION	NOTE
1	TTR-3601	STEP	
2	TTR-3602	STEP MAT	
3	TTR-3603	STEP BRKT	
201	050-U00400	U NUT M4	
202	060-F00400	FLT WSHR M4	

27 ASSY PWR SPLY (TTR-4000)

(D-1/2)

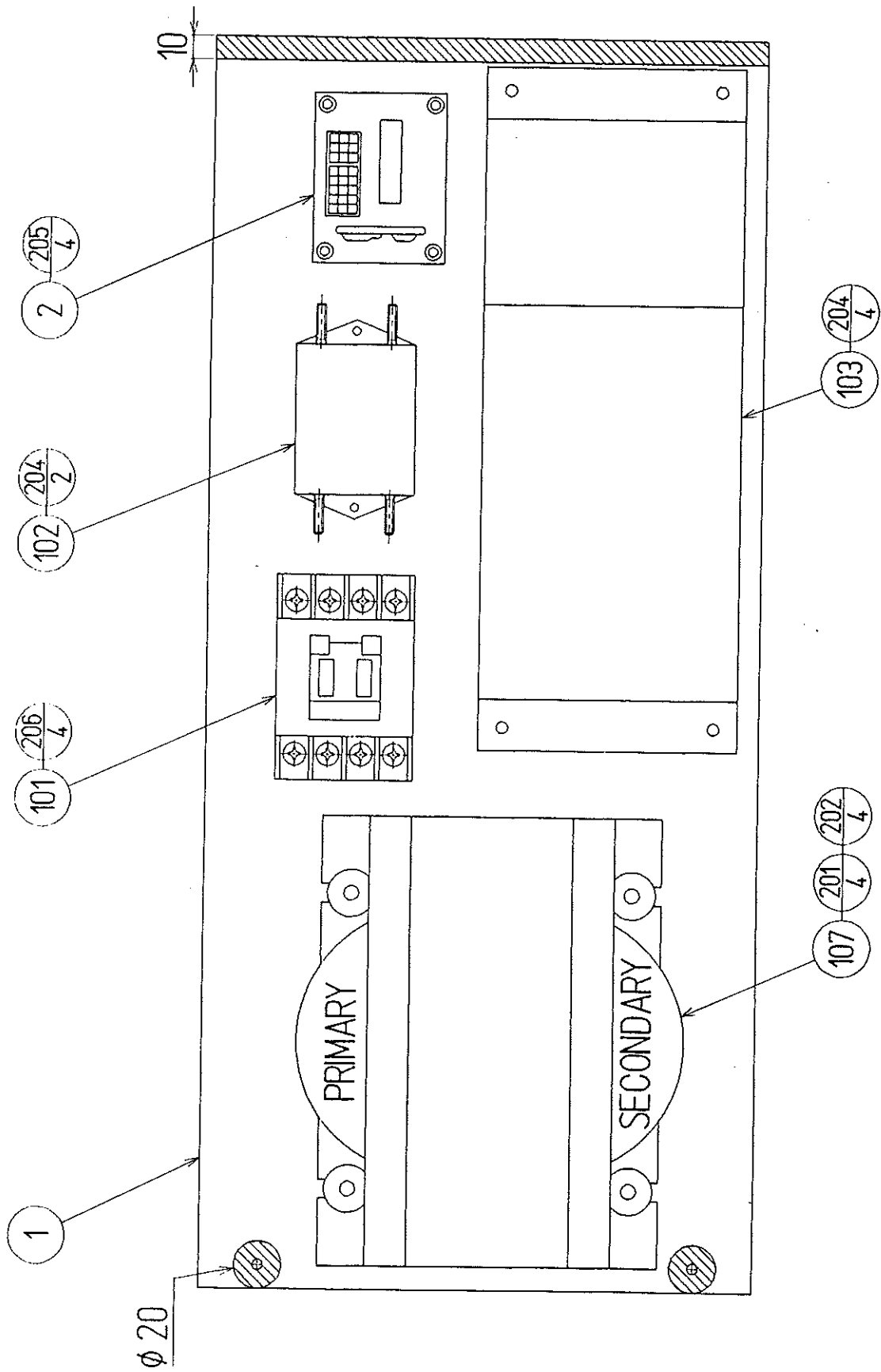

②7 ASSY PWR SPLY (TTR-4000)

(D-2/2)

ITEM NO.	PART NO.	DESCRIPTION	NOTE
1	TTR-4001	PWR SPLY BASE	
2	838-10801	CONN BD B	
101	450-5090	MAGNET CONTACT SC-03 AC110V 1A	AC110V~120V AREA
	450-5091	MAGNET CONTACT SC-03 AC240V 1A	AC240V AREA
	450-5092	MAGNET CONTACT SC-03 AC220V 1A	AC220V AREA
102	270-5026	NOISE FILTER 20A	
103	400-5264	SW REGU +5V12A, 12V1.5A, -5V.1A	
104	280-5009	CORD CLAMP ϕ 21	
105	280-0419	HARNESS LUG	
106	601-0460	PLASTIC TIE BELT 100MM	
107	560-5259X	PWR XFMR 844VA	
201	000-P00514-W	M SCR PH W/FS M5 \times 14	
202	068-552016	FLT WSHR 5.5-20 \times 1.6	
203	011-F00310	TAP SCR FH 3 \times 10	
204	011-T00312	TAP SCR TH 3 \times 12	
205	011-T00325	TAP SCR TH 3 \times 25	
206	011-T03516	TAP SCR TH 3.5 \times 16	
301	600-6659-02	WIRE HARN PWR SPLY1	
302	600-6659-03	WIRE HARN PWR SPLY2	
303	600-6659-05	WIRE HARN PWR SPLY4	
304	600-6659-06	WIRE HARN PWR SPLY5	
305	600-6659-07	WIRE HARN PWR SPLY6	
306	600-6659-08	WIRE HARN PWR SPLY7	

②⑧ ASSY SOUND BD BASE (TTR-4100)

(D-1/2)

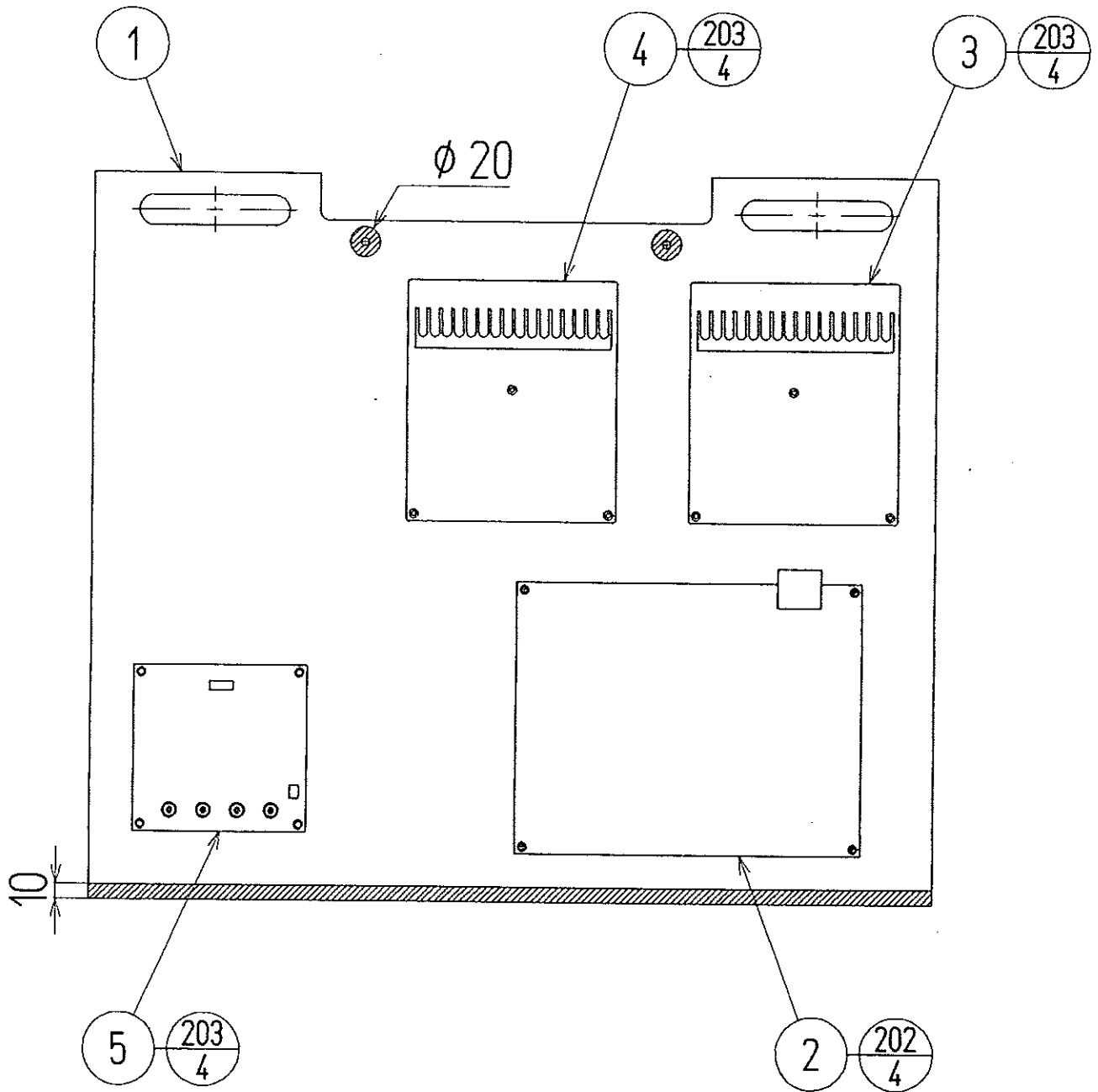

②8 ASSY SOUND BD BASE (TTR-4100)

(D-2/2)

ITEM NO.	PART NO.	DESCRIPTION	NOTE
1	TTR-4101	SOUND BD BASE	
2	837-12279	SOUND BD MANX T, T	
3	838-11650-11	EQ. PWR AMP MANX T, T DX A	
4	838-11650-12	EQ. PWR AMP MANX T, T DX B	
5	839-0582	VPM BUFFER BD	
101	280-5009	CORD CLAMP ϕ 21	
102	280-0419	HARNESS LUG	
201	011-F00310	TAP SCR FH 3 \times 10	
202	011-F00312	TAP SCR FH 3 \times 12	
203	011-T00325	TAP SCR TH 3 \times 25	
204	011-T00312	TAP SCR TH 3 \times 12	
301	600-6659-12	WIRE HARN SOUND BD BASE1	
302	600-6659-13	WIRE HARN SOUND BD BASE2	
303	600-6659-14	WIRE HARN SOUND BD BASE3	
304	600-6659-15	WIRE HARN SOUND BD BASE4	
305	600-6659-16	WIRE HARN SOUND BD BASE5	
306	600-6659-17	WIRE HARN SOUND BD BASE6	
307	600-6659-18	WIRE HARN SOUND BD BASE7	

②⑨ ASSY DRIVE BD BASE (TTR-4200)

(D-1/2)

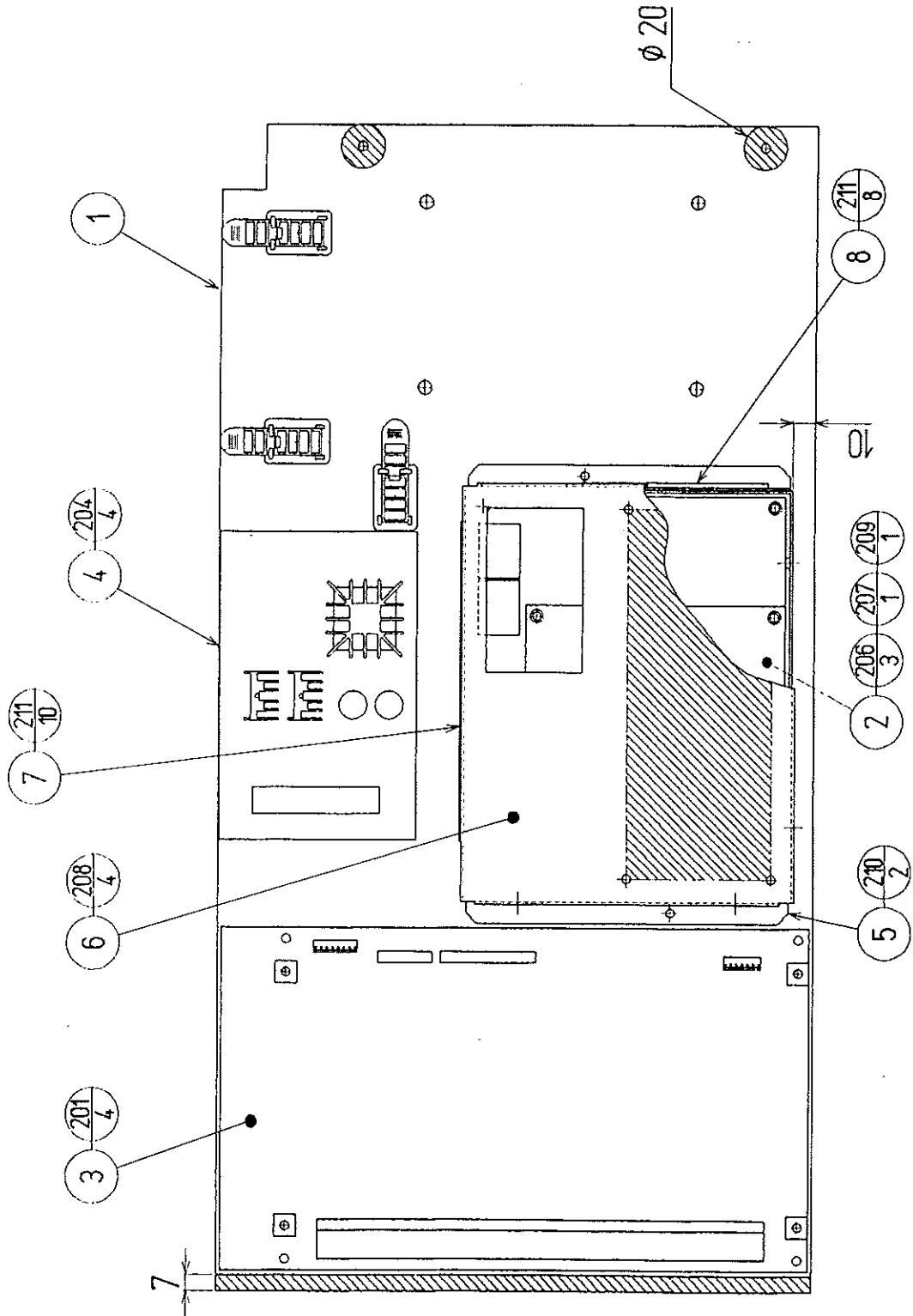

②9 ASSY DRIVE BD BASE (TTR-4200)

(D-2/2)

ITEM NO.	PART NO.	DESCRIPTION	NOTE
1	TTR-4201	DRIVE BD BASE	
2	838-12278	DRIVE BD MANX T. T DX	
3	838-12289	SERVO MOTOR DRIVER	
4	839-0451-01	LIGHT CONTROL BD TTR	
5	TTR-4202	SHIELD CASE	
6	TTR-4203	SHIELD CASE LID	
7	839-0829	FLT BD DRIVE CONTROL BD A	
8	839-0830	FLT BD DRIVE CONTROL BD B	
101	280-5009	CORD CLAMP ϕ 21	
102	280-0419	HARNESS LUG	
201	011-T00310	TAP SCR TH 3 \times 10	
202	011-T00312	TAP SCR TH 3 \times 12	
204	011-T00325	TAP SCR TH 3 \times 25	
205	011-F00310	TAP SCR FH 3 \times 10	
206	000-P00308-W	M SCR PH W/FS M3 \times 8	
207	000-P00330-W	M SCR PH W/FS M3 \times 30	
208	000-P00408-W	M SCR PH W/FS M4 \times 8	
209	050-H00300	HEX NUT M3	
210	011-P03512	TAP SCR PH 3.5 \times 12	
211	010-P00308-F	S-TITE SCR PH W/F M3 \times 8	
301	600-6659-09	WIRE HARN DRV BD BASE1	
303	600-6659-11	WIRE HARN DRV BD BASE3	
305	600-6659-63	WIRE HARN DRV BD BASE4	
306	600-6659-64	WIRE HARN SHIELD CASE 10P	
307	600-6659-65	WIRE HARN SHIELD CASE 12P	
308	600-6659-66	WIRE HARN SHIELD CASE 18P	
309	600-6609-64	WIRE HARN SHIELD CASE 8P	
310	600-6609-66	WIRE HARN SHIELD CASE 11P	
/	560-5304	AUTO XFMR AC100V 10A	
/	000-P00516-W	M SCR PH W/FS M5 \times 16	

30 ASSY HANDLE MECHA (610-0391)

(D-1/3)

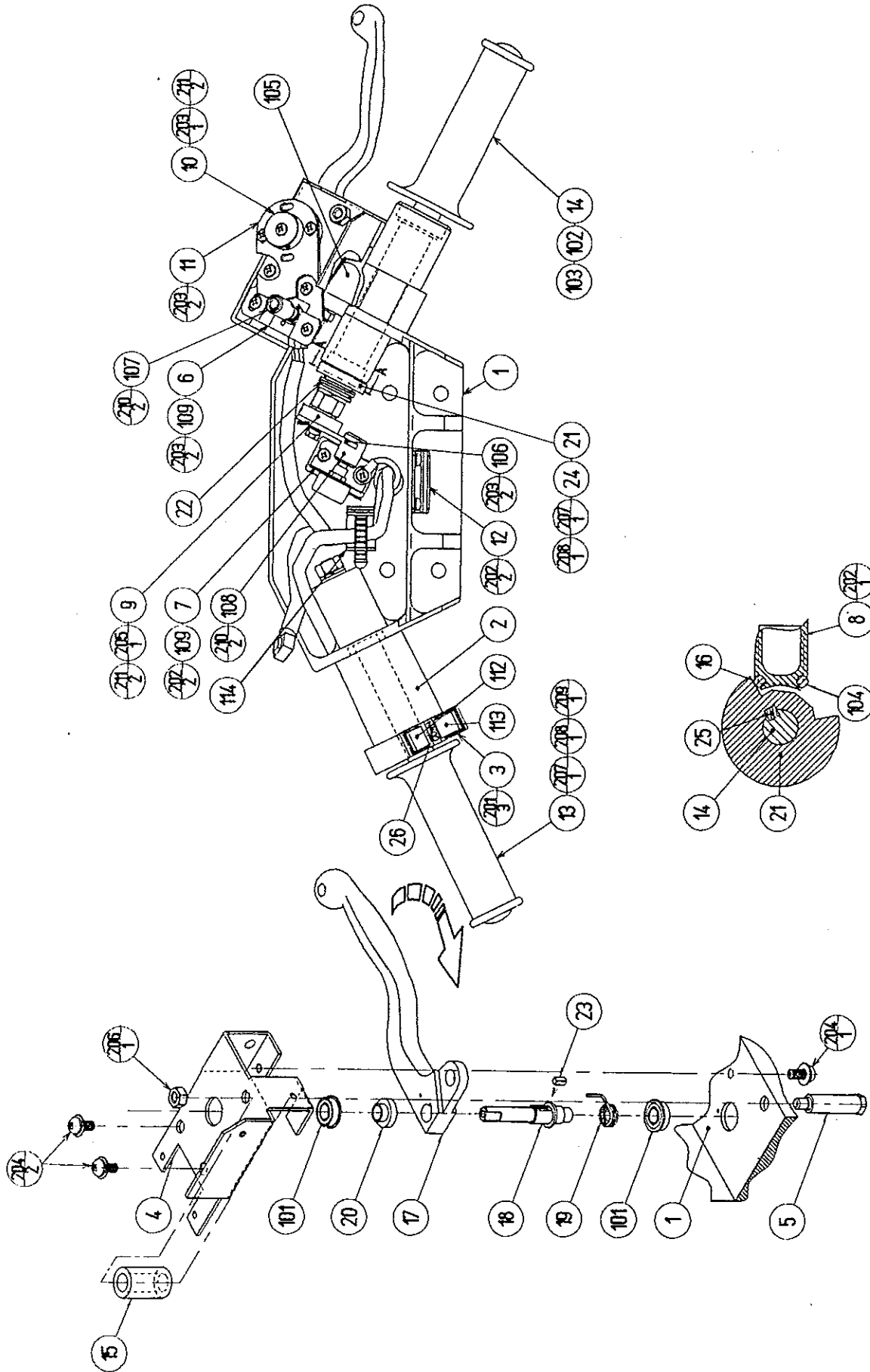

DETAILS: BRAKE PORTION'S ASSY

③ ASSY HANDLE MECHA (610-0391)

(D-2/3)

ITEM NO.	PART NO.	DESCRIPTION	NOTE
1	TTR-2001	HANDLE BASE	
2	TTR-2002	HANDLE LEFT	
3	TTR-2003	SW COVER	
4	TTR-2004	LEVER HOLDER UPPER	
5	TTR-2005	STOPPER SHAFT	
6	TTR-2006	BRAKE VOL BRKT	
7	TTR-2007	ACCEL VOL BRKT	
8	TTR-2008	STOPPER LID	
9	TTR-2009	GEAR HOLDER 80	
10	TTR-2010	GEAR HOLDER 110	
11	TTR-2011	GEAR 110	
12	TTR-2012	COVER HOLDER BRKT	
13	TTR-2013	GRIP L	
14	TTR-2014	GRIP R	
15	TTR-2015	STOPPER RUBBER	
16	TTR-2016	ACCEL STOPPER	
17	COL-2202	BRAKE LEVER	
18	COL-2203	LEVER SHAFT	
19	COL-2204	TORSION SPRING 1, 2	
20	COL-2205	LEVER COLLAR	
21	COL-2215	STOPPER DISK	
22	GPD-2009	TORSION SPRING	
23	GLC-2218	KEY 3×3×7	
24	HSD-2017	SPRING HOLDER	
25	HSD-2019	KEY 4×4×12	
26	421-9016	STICKER SHIFT UP/DOWN	
101	100-5041	BEARING	
102	100-5111	BEARING ϕ 12	
103	100-5112	BEARING ϕ 17	
104	100-5228	BEARING PIN 4×19.8	
105	601-5564	STOPPER	
106	601-6005	ADJUST GEAR	
107	601-7944	GEAR 15	
108	601-7945	GEAR 20	
109	220-5484	VOL CONT B-5KOHM	
110	310-5029-D20	SUMITUBE F D20MM	
111	601-0460	PLASTIC TIE BELT 100MM	
112	509-5724	PUSH BUTTON SW GREEN	
113	509-5725	PUSH BUTTON SW RED	
114	280-5008	CORD CLAMP ϕ 15	
201	000-F00308	M SCR FH M3×8	
202	000-P00408-W	M SCR PH W/FS M4×8	
203	000-P00412-W	M SCR PH W/FS M4×12	
204	000-P00512-W	M SCR PH W/FS M5×12	
205	050-U00500	U NUT M5	
206	050-U00600	U NUT M6	
207	050-H01200	HEX NUT M12	
208	060-S01200	SPR WSHR M12	
209	060-F01200	FLT WSHR M12	
210	028-A00306-P	SET SCR HBX SKT CUP P M3×6	

③ ASSY HANDLE MECHA (610-0391)

(D-3/3)

ITEM NO.	PART NO.	DESCRIPTION	NOTE
211	028-A00408-P	SET SCR HEX SKT CUP P M4×8	
301	600-6659-45	WIRE HARN HANDLE UNIT 1	
303	600-6659-52	WIRE HARN HANDLE UNIT 3	
304	600-6659-60	WIRE HARN EARTH HANDLE UNIT	

19. WIRE COLOR CODE TABLE

THE WIRE COLOR CODE is as follow:

- A PINK
- B SKY BLUE
- C BROWN
- D PURPLE
- E LIGHT GREEN

Wires other than those of any of the above 5 single colors will be displayed by 2 alphanumeric characters.

- 1 RED
- 2 BLUE
- 3 YELLOW
- 4 GREEN
- 5 WHITE
- 7 ORANGE
- 8 BLACK
- 9 GRAY

If the right-hand side numeral of the code is 0, then the wire will be of a single color shown by the left-hand side numeral (see the above).

Note 1: If the right-hand side alphanumeric is not 0, that particular wire has a spiral color code. The left-hand side character shows the base color and the right-hand side one, the spiral color.

<Example> 51 WHITE / RED

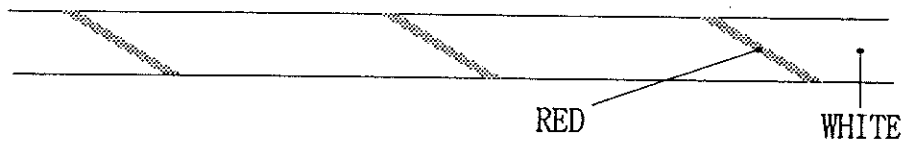

Note 2: The character following the wire color code indicates the size of the wire.

- K: AWG18, UL1015
- L: AWG20, UL1007
- None: AWG22, UL1007